

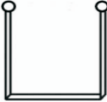























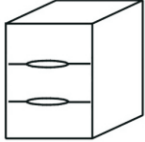

# NEW U-DS90W/U-DS90B Creation Station Assembly Instructions

Additional Tool needed: Phillips Screwdriver

## Parts List

[A] - 24" x 40" Top (1 piece) 	[H] - Drawer Supports (4 pieces) 	[O] - 6 x55mm (6 pieces) 	[V] - Washer (4 pieces) 
[B] - Upper Base End (2 pieces) 	[I] - Tilt Mechanism (2 pieces) 	[P] - 6 x 28mm (8 pieces) 	[W] - Allen Wrench (1 piece) 
[C] - Lower Base End (2 pieces) 	[J] - Top L-Bracket (2 pieces) 	[Q] - 5x14mm (8 pieces) 	[X] - Wrench (1 piece) 
[D] - Foot Bar (1 piece) 	[K] - Drawer Supports Rods (4 pieces) 	[R] - 4 x 12mm (2 pieces) 	[Y] - Wrench with hole (1 piece) 
[E] - Cross Support (1 piece) 	[L] - Castors (2 Locking & 2 non-locking) 	[S] - Nuts (4 pieces) 	[Z] - Drawers (2 sets - these need to be assembled) Please see assembly sheet for drawers. 
[F] - Top Support (1 piece) 	[M] - Cross Support End Cap (2 pieces) 	[T] - 6x65mm (6 pieces) 	
[G] - Pencil Ledge (1 piece) 	[N] - Footbar Spacers (2 pieces) 	[U] - Collars - includes knob and bolt (4 pieces) 	

### IMPORTANT

If you have difficulty assembling your U-DS90W Creation Station or need customer service assistance. Please call:

**Martin Universal Design, Inc.**  
Customer Service Hot Line at  
1-313-895-0700.

If you need additional parts,  
it is not necessary to contact your dealer,  
our Customer Service Rep. will forward them  
to you immediately.

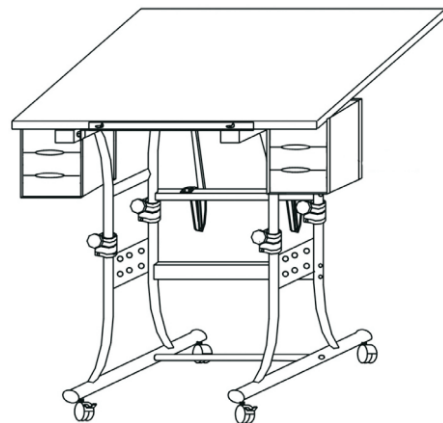

Pg. 1

# NEW U-DS90W/U-DS90B Creation Station Assembly Instructions

## STEP 1] Assembly Base of Table

Begin by taking the [2] Lower Base End units (part C) and attach the foot bar (part D) to the lower Base End units using a foot bar spacer (part N) between each end of foot bar and base end unit. Secure with [2] 6x65mm bolts (part O). Loosely fasten bolts with Allen Wrench to allow for further assembly of next step . See FIG 1.

Attach Cross support (part E) to each Base End Unit (part C). First, attach the Cross Support End Caps (part M) to each end of Cross Support. Continue by securing cross support to leg of base unit with [2] 6x65mm bolts (part T). Tighten with Allen Wrench and go back to tighten down foot bar assembly bolts (part O) . See FIG 1.

Complete Step 1 by inserting [2] locking castors (part L) into the front of the base end. Complete by inserting the [2] remaining non-locking castors into the rear of the base. Tighten down with wrench (part V). See FIG 1.

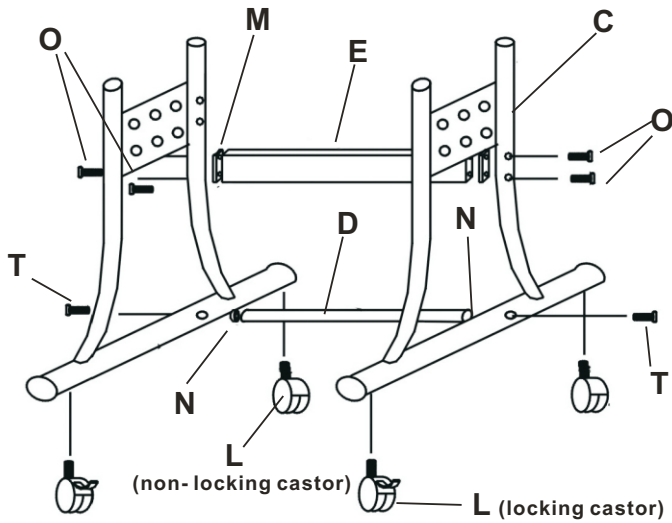

FIG 1

## STEP 2] Assembly Top portion of Base

Take each upper Base end (part B) attach to Top Surface Cross Support (part F) using [2] 6x55mm bolts (part O). Tighten and secure with Allen Wrench. See FIG 2.

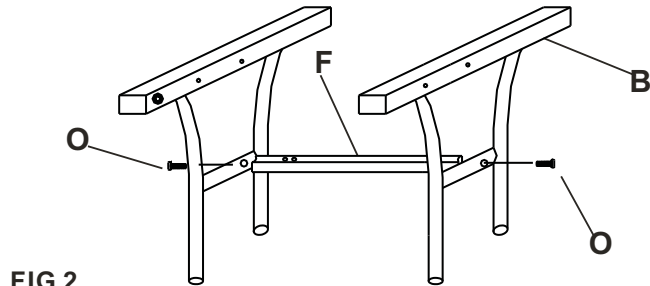

FIG 2

## STEP 3] Complete Base Assembly

Before combining the top portion to the bottom portion, slide the collars (part K) onto each of the [4] ends of the lower portion of the base. Tighten lower bolt found below knob on collar. This secures collar to leg. Repeat with all 4 collars. See FIG 3.

Once the collars are on the base, insert the top portion into the lower portion of the base making sure the top ends slide into the collars that are on the lower portion of the base. Secure with the [4] male knobs into the collars and tighten. See FIG 3.

**NOTE: Knobs on collars are to secure table at desired height.**

**NOTE: Knobs should face inside Part C Lower Base End.**

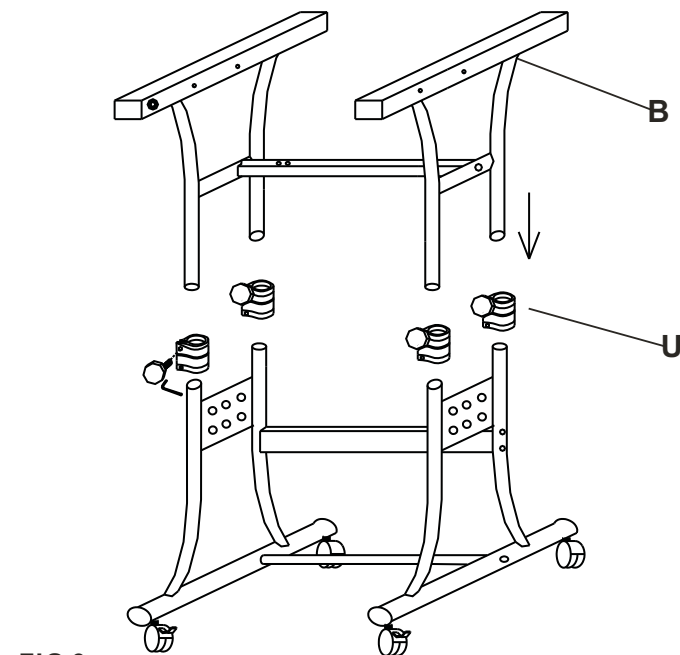

FIG 3

# NEW U-DS90W/U-DS90B Creation Station Assembly Instructions

## STEP 4] Attaching Tilt Mechanism

Take the [2] Tilt Mechanisms (part I) and attach the one end as show in FIG 4 to the Top Support (part F) using [2] 6x28mm bolts (part P) and [2] nuts (part S) per tilt mechanism. Tighten with wrench (part U) and Allen Wrench. Repeat with other mechanism. See FIG 4.

## STEP 4B] Attaching Drawer Supports

Attach drawer support (part H) to drawer support rod (part K) using (part P) 6x28mm bolt. Continue by attaching drawer support (part H) to upper base end (part B) using (part T) 6x65mm add (part V) between upper base end and (part H) drawer support. Repeat assembly with the remaining drawer supports. SEE FIG 4B

FIG 4

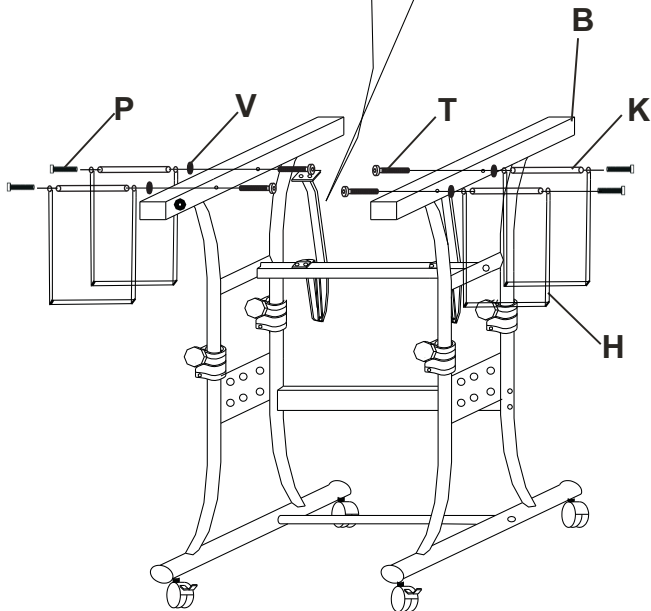
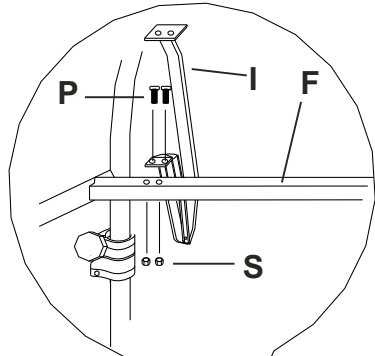
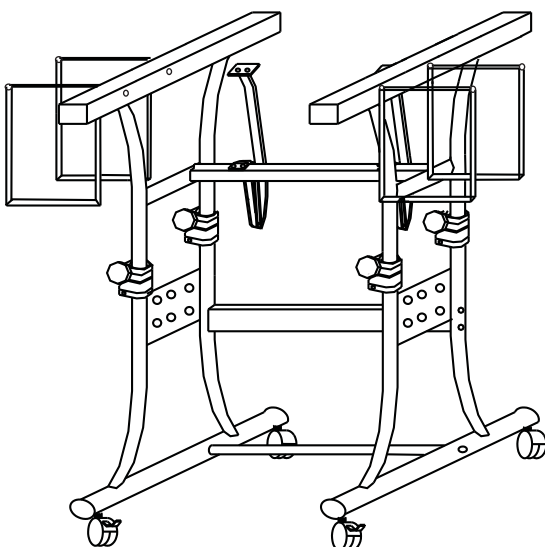

FIG 4B

After the previous steps, the Assembled Base should now look like the picture shown at left if proper assembly was completed.

Continue with assembly on next page.



# NEW U-DS90W/U-DS90B Creation Station Assembly Instructions

FIG 5

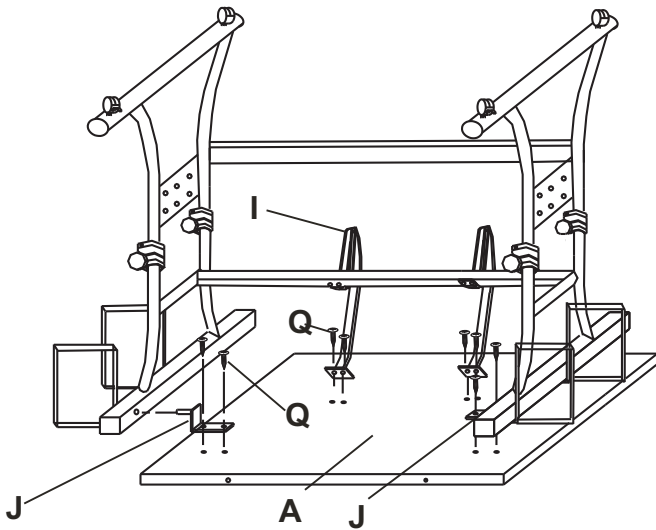

## STEP 5] Attach Top to Base

**NOTE: Use [2] people to help each other turn base over onto Table Top.**

Lay Table Top onto flat carpeted surface or empty flattened carton insuring top wont scratch, making sure the T-nut holes are facing up.

Now, place Base upside down onto top by lining up holes in Tilt Mechanism (part I) with proper holes in top.

Note: The other [4] holes in top are for the L-Brackets(part J). Secure top to base using [2] each 5x14mm bolts (part Q) per tilt mechanism (part I). Secure with Allen Wrench. Repeat with other Tilt Mechanism.

Attach L-Brackets (part J) by inserting rod found on L-Bracket into base, complete by attaching L-bracket to top using [2] each 5x14mm bolts (part Q) per L-bracket. Secure with Allen Wrench. Repeat with other side. See FIG 5.

FIG 6

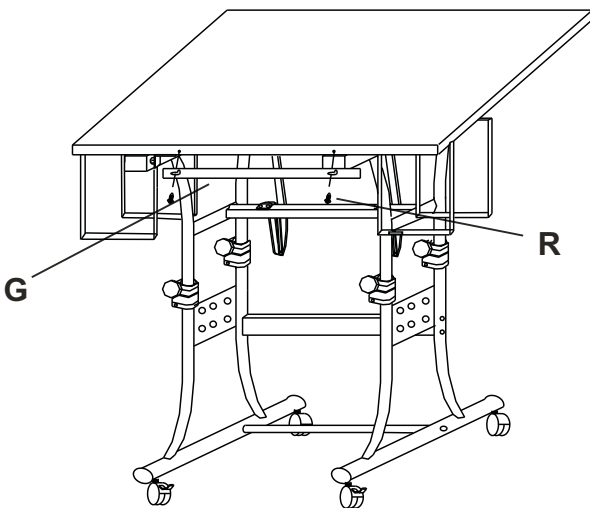

## STEP 6] Attachment of Pencil Edge

**NOTE: Use [2] people to help each other turn base over onto Castors.**

Attach Pencil Edge (part G) to front edge of Top using [2] each 4x12mm screws (part R). Tighten to secure. NOTE: Keep screw slightly loose to allow for raising or lowering of pencil edge. SEE FIG 6.

FIG 7

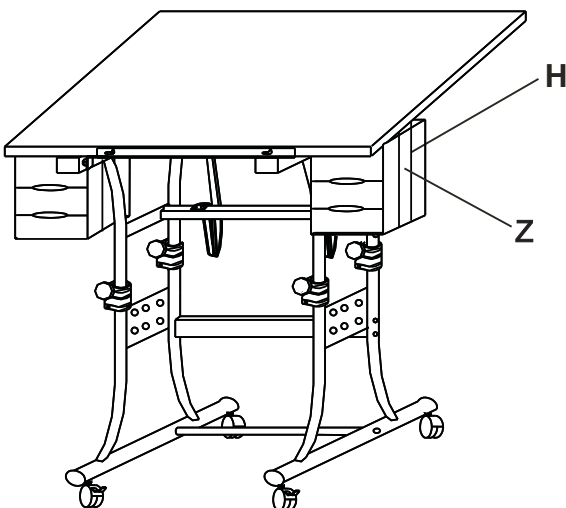

## STEP 7] Drawer Assembly

See Drawer Assembly Instruction sheet for assembly.

Assemble Drawers (part Z) and then slide them into the Drawer Supports (part H) found hanging on either side of the table. Make sure the drawer fronts are facing the front of the table. SEE FIG 7.

Once complete, double check all screws and bolts to make sure they are secure.

Table is now ready for your enjoyment!

WEBER  
V

**MARTIN**  
Universal Design, Inc.

4444 Lawton Avenue, Detroit, MI 48208 USA • Tel:(313)895-0700/Fax:(313)895-0709  
Email: Custservmud@aol.com • visit us at [www.MartinUniversalDesign.com](http://www.MartinUniversalDesign.com)



# NEW U-DS90W/U-DS90B Creation Station Drawer Assembly Instructions

## Drawer Parts & Quantity (makes 2 Drawer Banks)

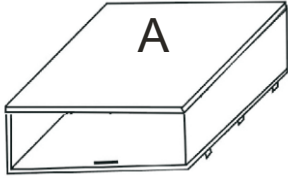

Top - 2 Pieces

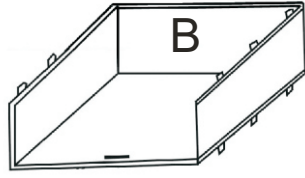

Inside Section - 2 Pieces

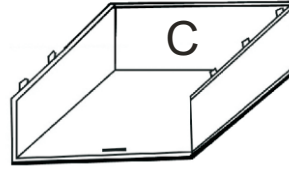

Bottom - 2 Pieces

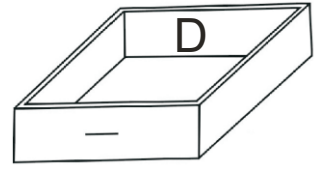

Drawers - 6 Pieces

**WARNING: READ ALL INSTRUCTIONS FIRST BEFORE ASSEMBLING DRAWERS.  
ONCE PIECES ARE SNAPPED TOGETHER THEY ARE SECURED.**

Assemble your drawers by taking the section [A] and snapping into place - by lining up the tabs with the grooves in the outside edge of section piece [B]. Complete by snapping section [C] onto section A&B.

Finish by sliding the [3] Drawers into the drawer bank assembly.

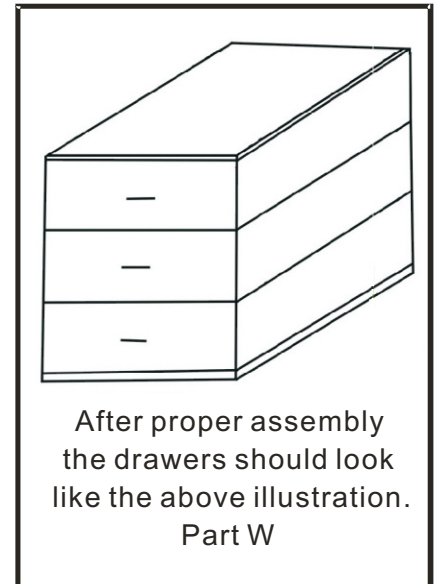
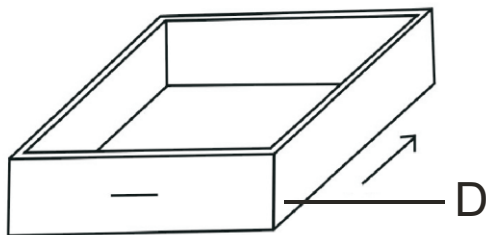
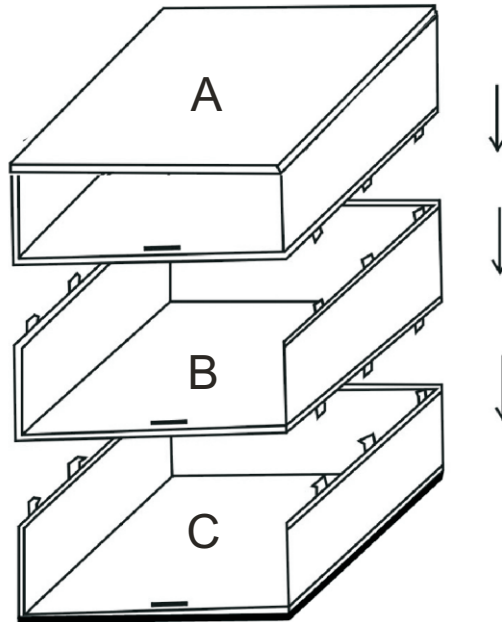

### IMPORTANT

If you have difficulty assembling your U-DS90W Drawers or need customer service assistance. Please call: Martin Universal Design, Inc. Customer Service Hot Line at 1-313-895-0700. If you need additional parts, it is not necessary to contact your dealer, our Customer Service Rep. will forward them to you immediately.



4444 Lawton Avenue, Detroit, MI 48208 USA • Tel:(313)895-0700/Fax:(313)895-0709  
Email: Custservmud@aol.com • visit us at [www.MartinUniversalDesign.com](http://www.MartinUniversalDesign.com)