

## IMPORTANT NOTICE

YOU WILL FEEL A SLIGHT  
 "BOUNCE-BACK" WHEN YOU SIT DOWN.  
 THIS IS NORMAL: NOT A DEFECT.  
 THE PNEUMATIC CYLINDER FOR THE  
 SEAT HEIGHT ADJUSTMENT REACTS TO  
 YOUR WEIGHT BY GIVING A LITTLE

# STANFORD Model's 91-1006 & 91-1009

## Parts

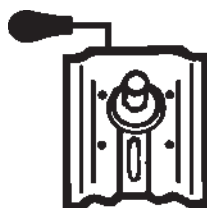

A. [1] Base Plate Mechanism



B. [1] Cylinder  
 [a] 91-1006 model  
 [b] 91-1009 model



C. [5] Castors



D. [1] Plastic Ring insert  
 Model 91-1006 only  
 (This part can be found in  
 the foot ring Part F)



E. [1] 5-Star Base



F. [1] Foot Ring with Knob  
 Model 91-1006 only.



G. [1] Backrest with Support bar



H. [1] Seat



I. [10] M6x20 Hex Head Screws



J. [1] Black Cylinder Bellows  
 Model 91-1009 only



K. [2] Loop Armrests



Assembled 91-1006



Assembled 91-1009

**MARTIN**  
 Universal Design, Inc.

4444 Lawton Avenue, Detroit MI 48208 USA

Tel:(313)895-0700 • Fax:(313)895-0709

E-mail: Custservmud@aol.com

Visit us at:

www.MartinUniversalDesign.com

**IMPORTANT**  
 If you have difficulty assembling your chair or need customer service assistance. Please call: Martin Universal Design, Inc. Customer Service Hot Line at 1-800-366-7337. If you need additional parts, it is not necessary to contact your dealer, our Customer Service Rep. will forward them to you immediately.

1. 

Place 5-star base (E) face down and push [5] castors (C) into each position.

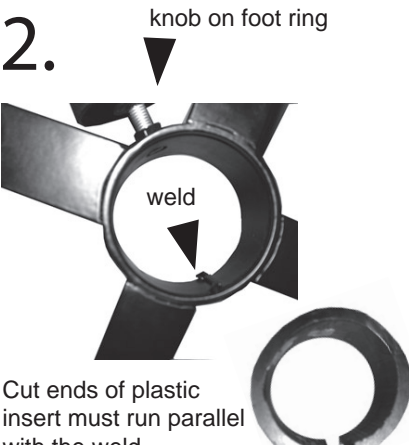
2. 

Cut ends of plastic insert must run parallel with the weld.

**THIS STEP IS ONLY FOR MODEL 91-1006 ONLY.**

Before attaching foot ring (F) to cylinder (B). Begin by loosening the knob on the foot ring and position the plastic ring insert properly, by making sure the cut ends of the insert run parallel with the weld on the inside of the foot ring hole. The insert should be already in the foot ring. **NOTE: THIS MUST BE POSITIONED PROPERLY TO ALLOW THE CYLINDER TO SLIDE THROUGH THE INSERT EASILY.**

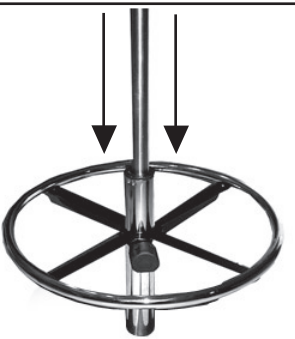
3. 

Slide cylinder down through foot ring and tighten knob. After chair is assembled completely, you may adjust foot ring to desired height.

4. 

**PLEASE NOTE: If you have model number 91-1009, your assembly will be the same but instead of foot ring you will need to place black bellows (J) over top of cylinder after inserting cylinder into base. Insert wider end of cylinder into hole in base, as shown above.**

5. 

Attach mechanism (A) to seat (H) using [4] M6x20 hex head screws (I) See picture above for specified locations that are circled. Tighten with hex wrench Attach as shown in the order pictured below::

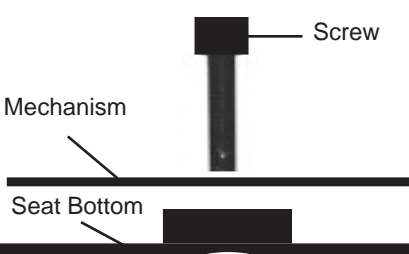

Mechanism  
Screw  
Seat Bottom

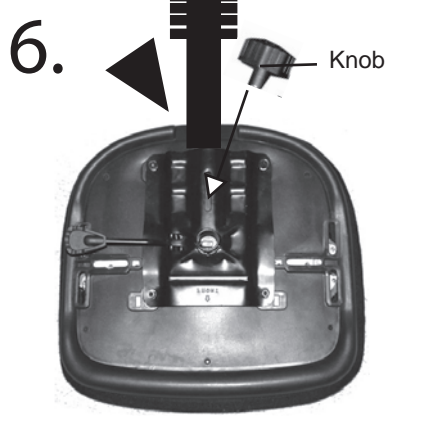
6. 

Attach back rest (G) to seat mechanism, by inserting backrest support bar into raised area of mechanism. Attach knob making sure it is positioned through mechanism and into hole in back support bar. Tighten knob to secure. **NOTE: This knob is also used for horizontal adjustment of backrest.**

7. 

Attach armrests (K) to bottom side of seat using [3] M6x20 screws (I) per armrest (K). Please see circled areas in the above picture for locations of screw holes. Tighten with hex wrench

8. 

Attach seat/backrest/armrest assembly to cylinder by inserting top of cylinder into hole on bottom of seat mechanism. Weight of sitting on seat will secure seat assembly to cylinder.

**NOTE: 2 Paddles below seat are for seat height adjustment and Backrest tilt adjustments.**