

Ridgeline

Assembly Instructions

U-DS6000P



IMPORTANT











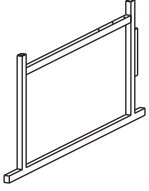

If you have difficulty assembling your U-DS6000P Ridgeline Table
or need customer service assistance. Please call:
Martin Universal Design, Inc. Customer Service Hot Line at 1-313-895-0700.
If you need additional parts, it is not necessary to contact your dealer,
our Customer Service Rep. will forward them to you immediately.

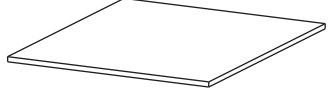

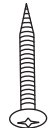
Martin Universal Design, Inc. • Detroit, MI 48208 USA
Tel: 313-895-0700 • E-mail: custservMUD@aol.com
www.MartinUniversalDesign.com

Ridgeline

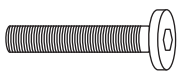
Hardware Parts List

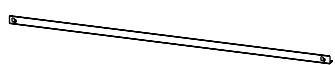
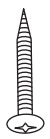
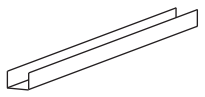
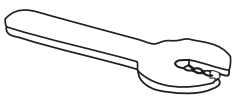
<p>A</p>  <p>2PCS Side Support</p>	<p>B</p>  <p>4PCS Floor Leveler</p>	<p>C</p>  <p>2PCS Panel</p>	<p>D</p>  <p>2PCS Height Adj. Tube w/ hole</p>
<p>E</p>  <p>1PC Top</p>	<p>F</p>  <p>2PCS Height Adj. Tube</p>	<p>G</p>  <p>2PCS Tilt Mechanism</p>	<p>H</p>  <p>14PCS 4x14mm Screw</p>
<p>I</p>  <p>4PCS Knob</p>	<p>J</p>  <p>12PCS 6x12mm Bolt</p>	<p>K</p>  <p>2PCS Small Washer</p>	<p>L</p>  <p>4PCS Large Washer</p>
<p>M</p>  <p>2PCS 8x50mm Bolt</p>	<p>N</p>  <p>2PCS Nut</p>	<p>O</p>  <p>1PC Pencil Edge</p>	<p>P</p>  <p>2PCS 4x12mm Screw</p>
<p>Q</p>  <p>2PCS Metal Guide</p>	<p>R</p>  <p>1PC Wrench</p>	<p>S</p> #6 Hex Wrench: A hexagonal Allen key." data-bbox="550 855 655 895"/> <p>1PC #6 Hex Wrench</p>	<p>T</p> #8 Hex Wrench: A hexagonal Allen key." data-bbox="755 835 900 890"/> <p>1PC #8 Hex Wrench</p>

Ridgeline Assembly

NOTE:

We recommend the
The Assembly of this table to be
performed with two adult people.

STEP 1

Begin assembly of the Ridgeline table by taking
the side support (part A) and attaching the
floor levelers (part B) to the side supports.
See Fig 1

FIG 1

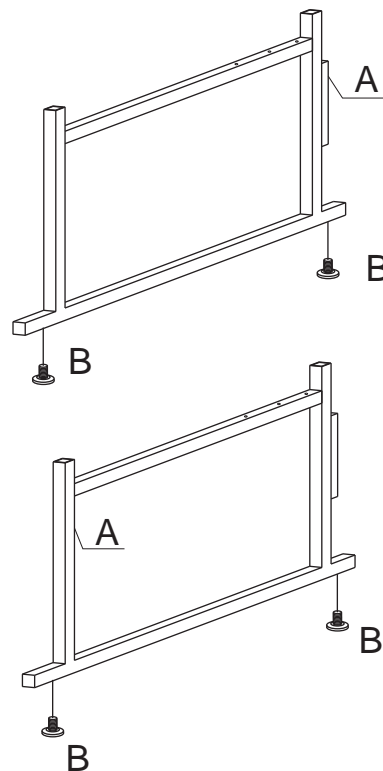

STEP 2

Continue by attaching the panel (part C)
to (part A) the side support, using 6 each
M6x12mm bolts (part J).
See Fig 2

FIG 2

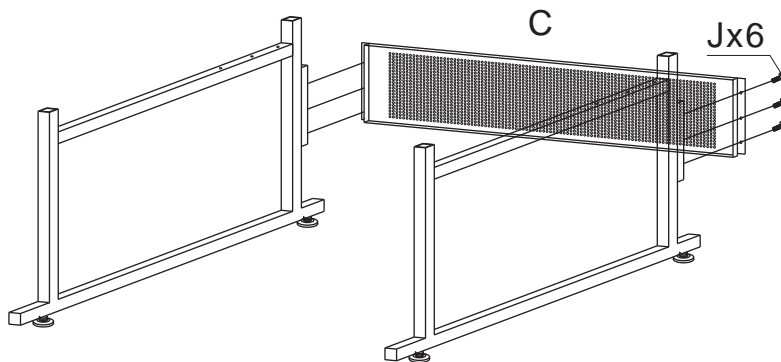

STEP 3

Attach the second panel (part C) to (part A)
by using 6 each M6x12mm bolts (part J).
See Fig 3

FIG 3

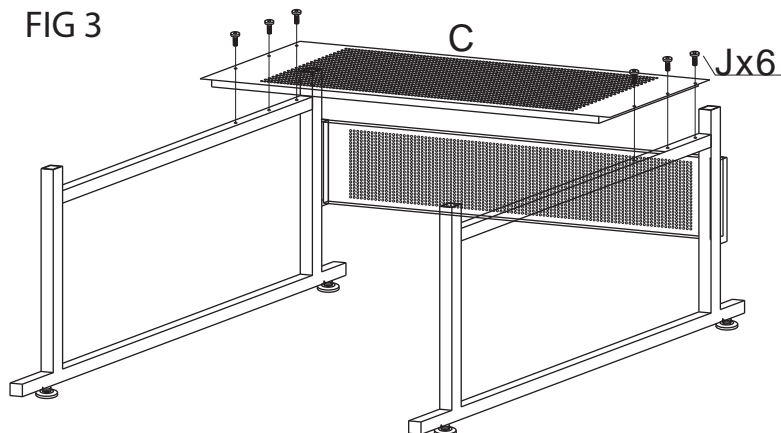

Ridgeline Assembly

STEP 4

Attaching Height Adjustment Tubes.

To attach the height adjustment tubes (part D + part F), use 4 each (part I) knob. Leave a 12" gap from the top of the side supports, and secure the tubes in place by tightening the tubes with the knobs. See Fig 4

FIG 4

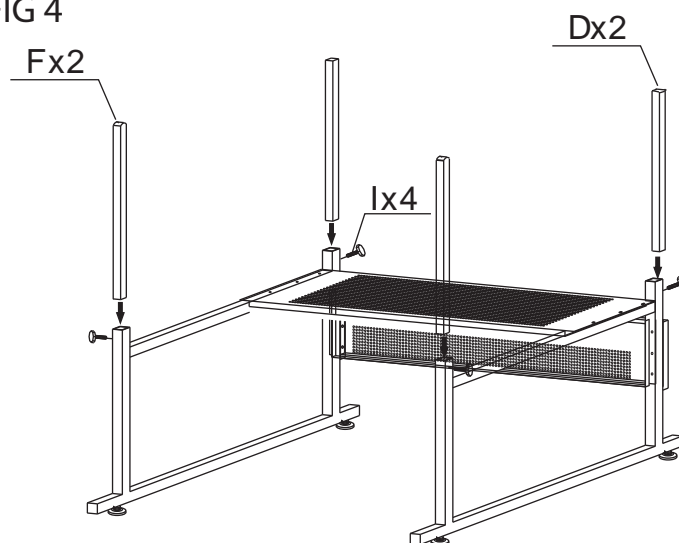

STEP 5A

Attach (part Q), metal guide, by using 6 each 4x14mm screws (part H).

See Fig 5

STEP 5B

Attach (part G), tilt mechanism, by using 8 each 4x14mm screws (part H).

See Fig 5

STEP 5C

Attach (part O) pencil edge to your desired position using 2 each 4x12mm screws (part P). There are no pre-drilled holes for pencil edge.

See Fig 5

FIG 5

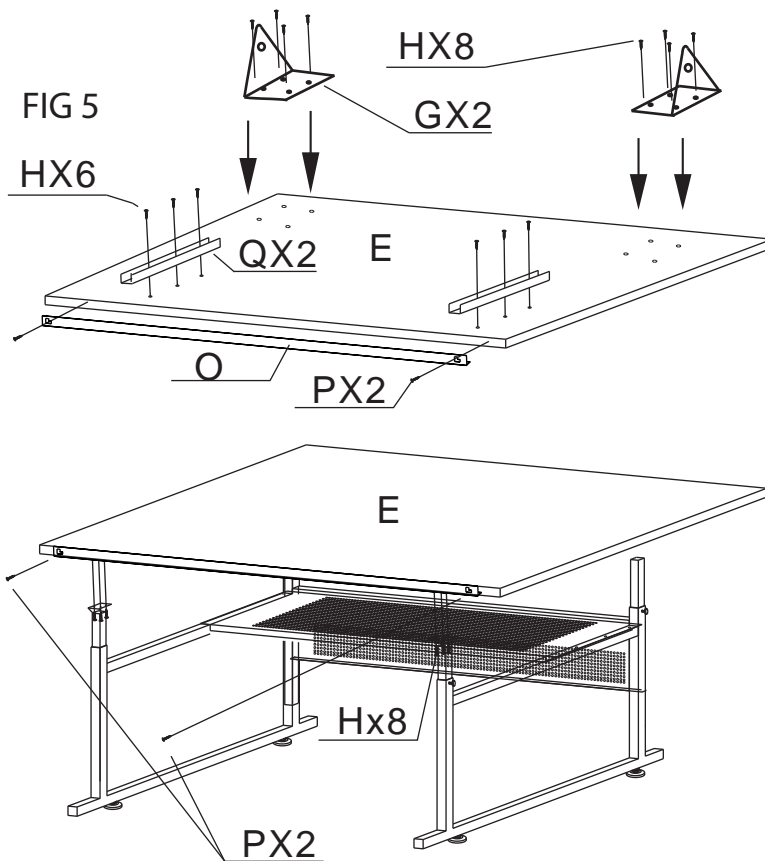

Ridgeline Assembly

STEP 6

Attach Base to Top

Attaching Tilt Mechanism to
Height Adjustment Tube.

To attach the tilt mechanism (part G) to the height adjustment tube, you will need the following parts 1 each (part M) 8x50mm bolt, 2 each (part L) washer, 1 each (part K) washer, 1 each (part N) nut. Follow the diagram in Figure 6 to attach the parts in the correct order. See Fig 6

FIG 6

