

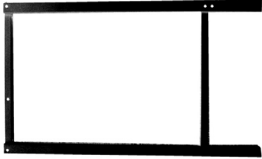



























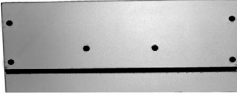

Manchester Split-top Table Assembly Instructions

Parts List

Part A - 1 piece 	Part B - 1 piece 	Part C - 1 piece 		
Part E - 1 piece 	Part G - 1 piece 	Part H - 1 piece 		
Part F - 1 piece 	Part I - 1 piece 	Part J - 1 piece 	Part K - 4 pieces 	Part L - 1 piece 
Part M - 2 pieces 	Part N - 10 pieces  6x50mm	Part O - 4 pieces  6x30mm	Part P - 3 pieces  6x8mm	
Part Q - 2 pieces  4x18mm	Part R - 3 pieces  4x30mm	Part S - 14 pieces  4x12mm	Part T - 4 pieces 	
Part U - 2 pieces 	Part V - 4 pieces 	Part W - 1 piece 	Part X - 1 piece 	
Part Y - 1 piece 	Part Z - 1 piece 	Part A1R - 1 piece 	Part A1L - 1 piece 	
Part B1 - 1 piece 	Part C1 - 1 piece 	Part D1 - 1 piece 	Part E1 - 4 pieces  4x35mm	

IMPORTANT

If you have difficulty assembling your Manchester Table or need customer service assistance. Please call: Martin Universal Design, Inc. Customer Service Hot Line at 1-313-895-0700. If you need additional parts, it is not necessary to contact your dealer, our Customer Service Rep. will forward them to you immediately.

Manchester DRAWER Assembly

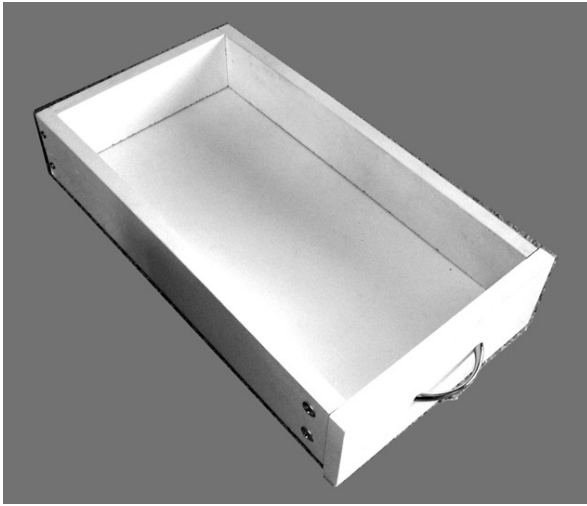

PLEASE NOTE:

Assemble the Drawer FIRST before assembling the base.
Once assembled, set drawer to side.

Assembled drawer to be used later
during assembly of table.

FIG A

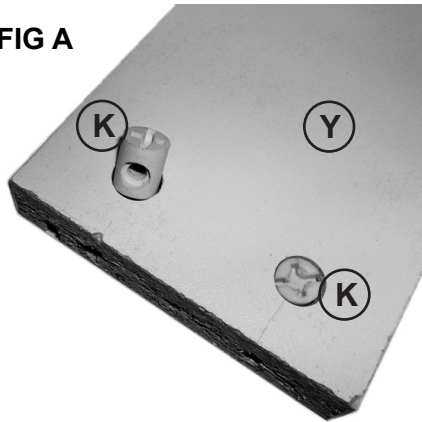

STEP 1] Assemble Drawer

Begin by taking the back panel of drawer (Part Y) and inserting 1 plastic T-nut (part K) into each hole, making sure the hole in the T-nut is lined up with the hole in the edge of the back panel. See FIG A.

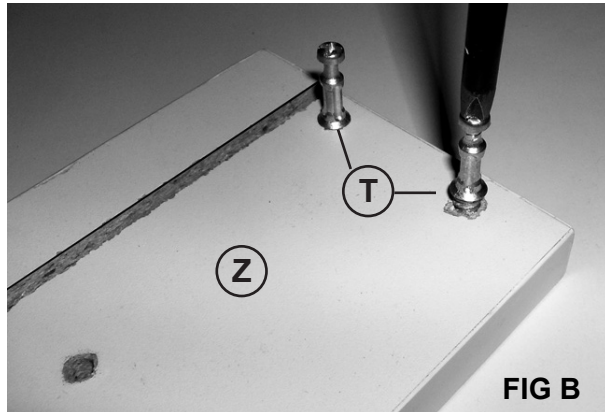

STEP 2] Assemble Drawer, cont'd.

Take the Drawer Front (Part Z) and insert the 4 Threaded Connector Pins (Part T). Use Phillips Screwdriver to secure Threaded Connector Pins into Drawer front.
See FIG B.

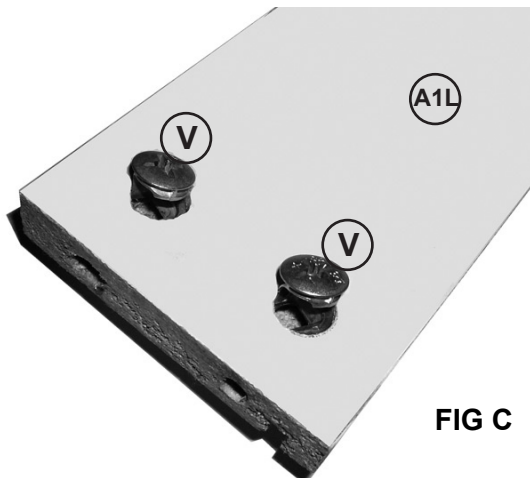

STEP 3] Assemble Drawer, cont'd

Take the Sides of the Drawer (Parts A1R & A1L) and insert the 2 T-nuts into the holes found on each side panel, making sure the holes of the T-nuts line up with the holes on the outer edge of the drawer sides.
See FIG C.

Manchester DRAWER Assembly

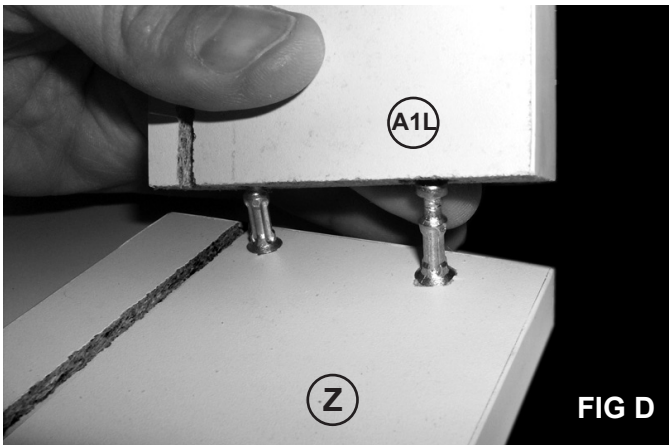

FIG D

STEP 4] Assemble Drawer, cont'd

Attach sides of drawers (Parts A1L & A1R) to the Drawer front (Part Z) by inserting Threaded Connection Pins into the holes on the outside edge of the Drawers sides (Parts A1L & A1R).

PLEASE NOTE: The Grooves in each side must be lined up with each other to allow the drawer bottom to be installed.

To secure, tighten the T-nuts found on the outer side of the drawer sides. Turn the T-nuts until tight. See FIG D



FIG E

STEP 5] Inserting Drawer Bottom

Slide the Drawer bottom (Part B1) into the grooves on the sides of the drawers and into the front of the drawer.

NOTE: Brown side of drawer bottom is the bottom of the drawer. White side up for inside drawer bottom.

See FIG E



FIG F



FIG G

STEP 6] Completing Drawer Assembly

Complete Drawer Assembly by attaching the Drawer back (Part Y) to the drawer by inserting the drawer bottom into the groove on the drawer back. See FIG F

To secure Drawer Assembly, insert 2 each 4x35mm screws (Part E1) into the drawer sides and tighten with phillips screwdriver, as shown in FIG G

Manchester DRAWER Assembly

STEP 7] Attaching Drawer Handle

Attach drawer handle (Part L) to drawer, using 2 each 4x18mm screws (Part Q). See FIG H

Insert screws (Part Q) through inside of drawer into appropriate holes and tighten with phillips screwdriver. Hold onto drawer handle while securing screws. See FIG I

Go back and double check all screws are tight on all sections of drawer.

Set Drawer aside and begin table assembly.

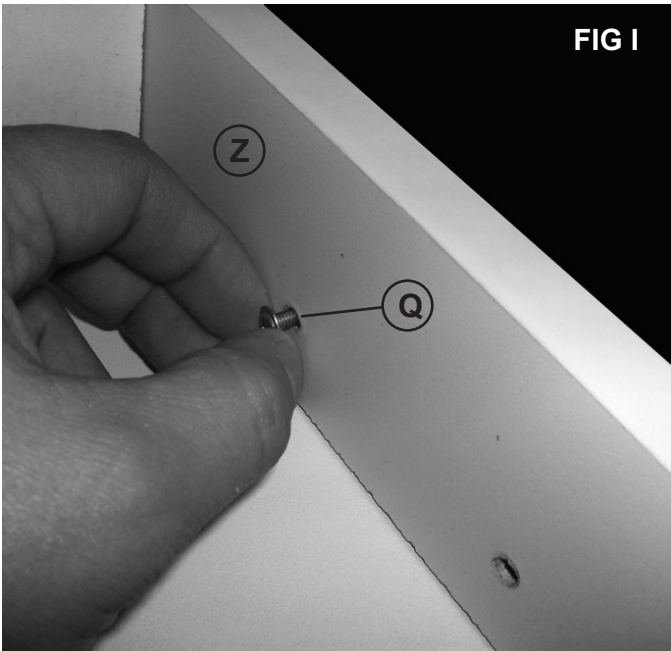
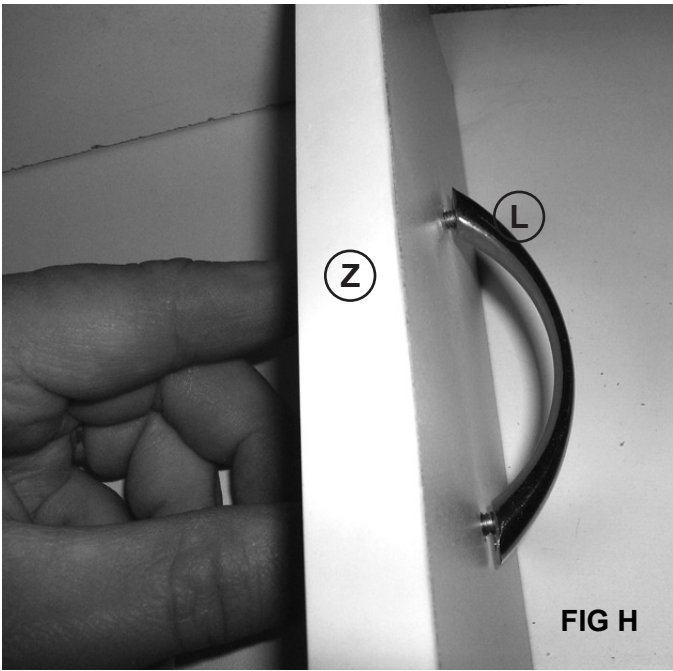

Manchester Split-top Table Assembly Instructions

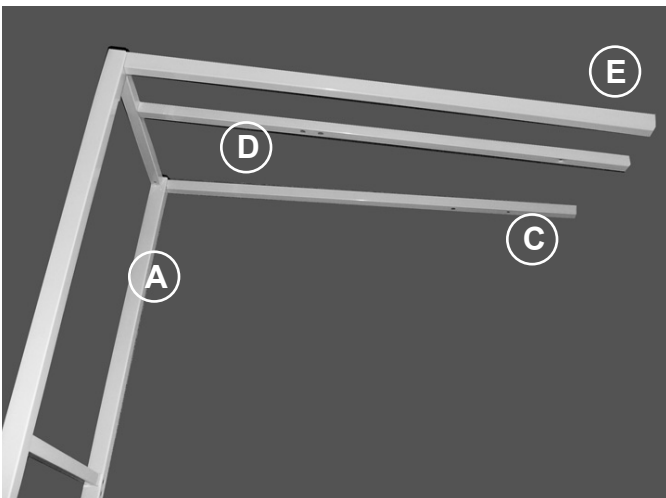
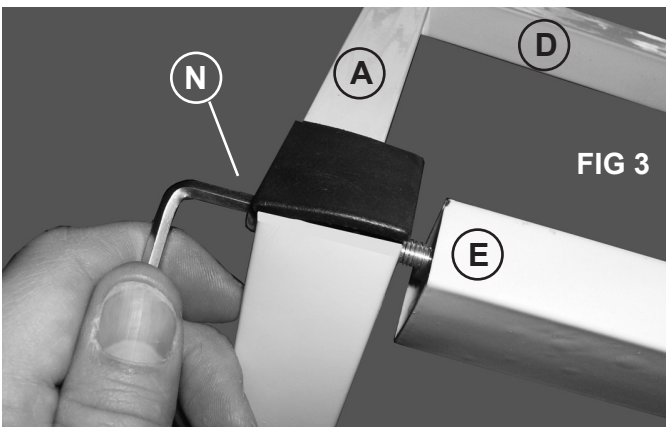
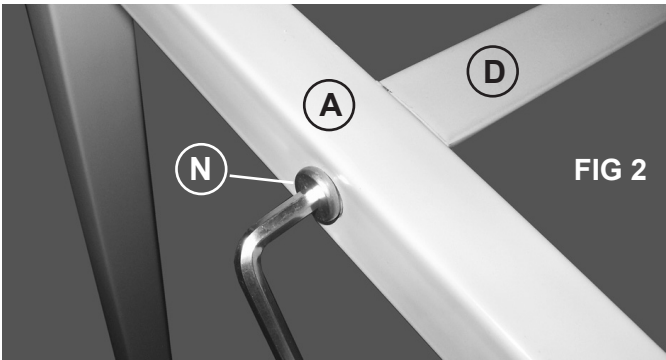
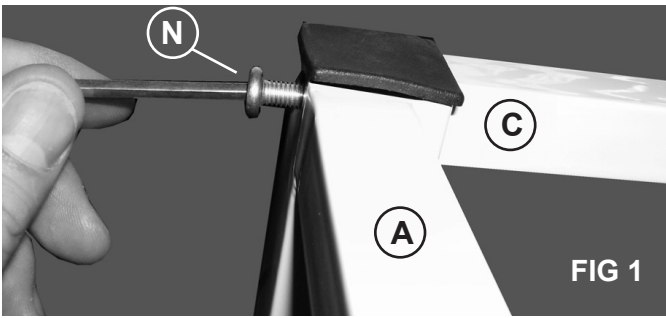

FIG 1

FIG 2

FIG 3

FIG 4

STEP 1] Assembly Base of Table

Begin by assembling the base by taking the left side (part A) and attaching the three cross supports (part C, D & E) using 1 each 6x50mm hex bolts (part N) into each hole found on the outside side edge of Part A and lining that hole up with the hole in the end of each cross support. Tighten hex bolt with Allen Wrench (part C1). SEE FIG 1,2 & 3

PLEASE NOTE: The Black square caps as shown in FIG 1 indicate the top side of Parts A & B

PLEASE NOTE: DO NOT OVERTIGHTEN HEX BOLT to cause frame to bend.

Attach cross support (part D) to Side A
FIG 2.

Attach cross support (part E) to Side A
FIG 3.

STEP 2] Assembly Base of Table, cont'd

This is what your partial assembled base should now look like. See FIG 4.

Manchester Split-top Table Assembly Instructions

STEP 3] Assembly Base of Table, cont'd

Repeat with right side (part B) by attaching the other end of the three cross supports (part C, D & E) using 1 each 6x50mm hex bolts (part N) into each hole found on the outside side edge of Part A and lining that hole up with the hole in the end of each cross support. Tighten hex bolt with Allen Wrench (part C1). SEE FIG 5,6 & 7

PLEASE NOTE: The Black square caps as shown in FIG 1 indicate the top side of Parts A & B

PLEASE NOTE: DO NOT OVERTIGHTEN HEX BOLT to cause frame to bend.

Attach cross support (part D) to Side A FIG 6.

Attach cross support (part E) to Side A FIG 7.

STEP 4] Assembly Base of Table, cont'd

This is what your partial assembled base should now look like. See FIG 8.

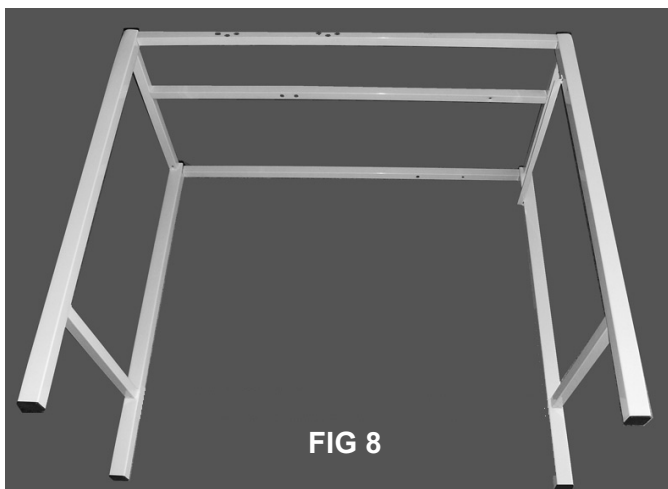
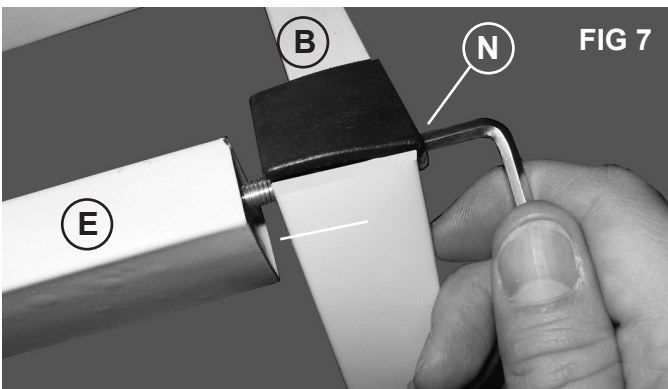
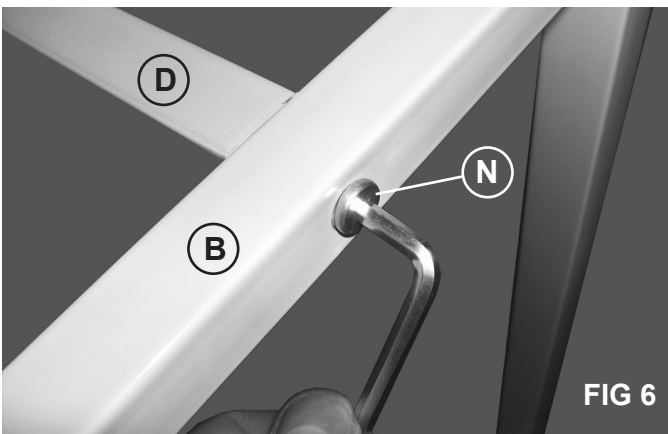
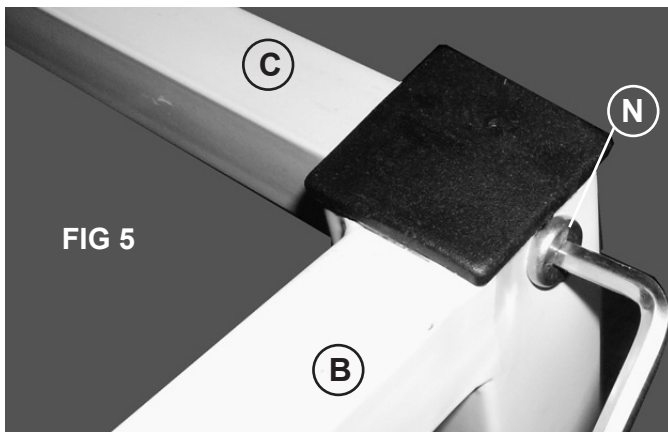

Manchester Split-top Table Assembly Instructions

STEP 5] Attach Lower Cross support

Attach lower wider Cross Support (part F) to lower portion of base by lining up the two holes on each end of Part A & B with the two holes found in each end of Part F. Secure by using two each 6x50mm Hex Bolts in each end.

SEE FIG 9.

PLEASE NOTE: DO NOT OVERTIGHTEN HEX BOLT to cause frame to bend.

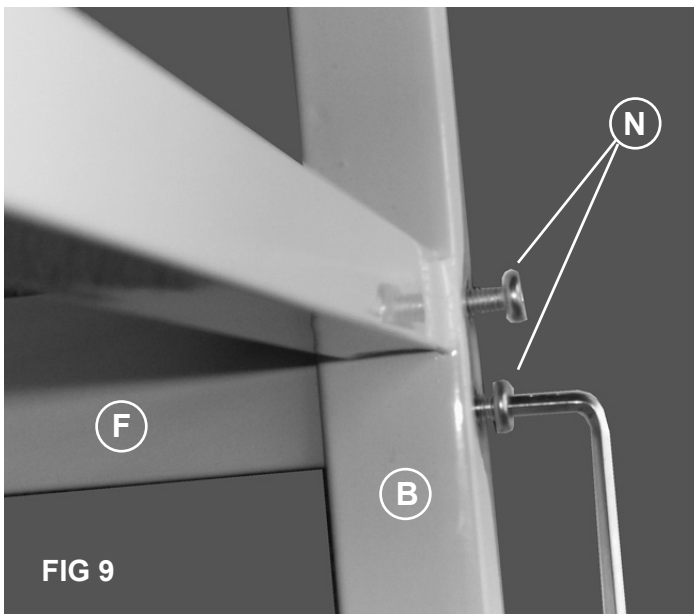

STEP 6] Assembly Base of Table, cont'd

If you assembled the base correctly, the assembled base should now look like FIG 10.

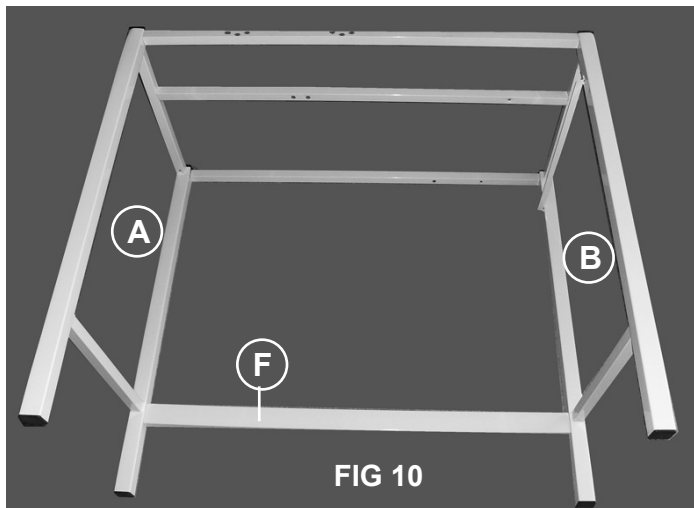

STEP 7] Attach Tilt Mechanism to Base

This step involves attaching the Tilt Mechanism (Part J) to the Base. Find the 2 holes on top side of cross support (part D). Secure Tilt Mechanism to this cross support using 2 each 6x30mm Hex Bolts (Part O) & 2 each Hex Nuts (Part U). The Nuts are to be positioned on the underside of cross support D. Use wrench (part D1) to hold nuts while tightening down Hex bolts. See FIG 11 & FIG 11B for proper positioning.

PLEASE NOTE: The elbow of the Tilt Mechanism is to be pointed to the rear of the table Base. See below for Photo that shows this.

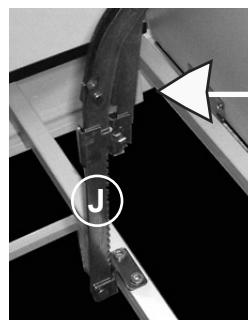
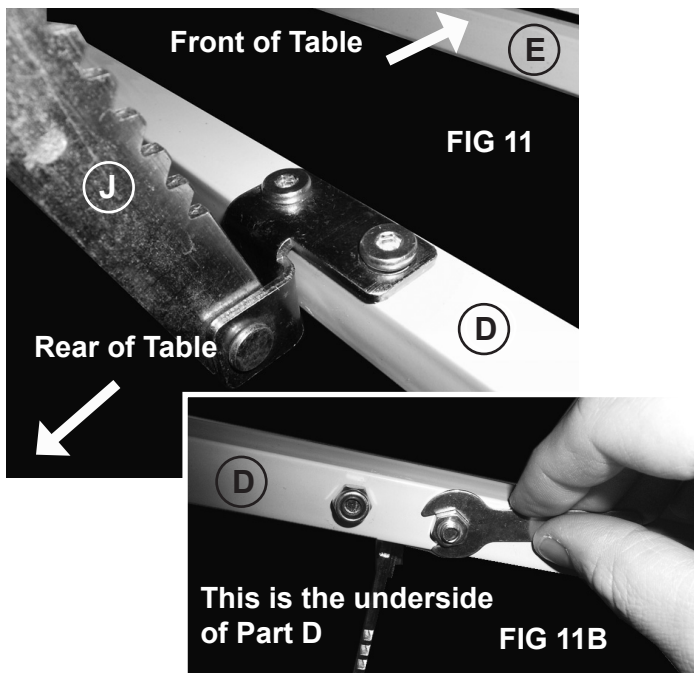

Elbow of the Tilt Mechanism faces the rear of the table

MARTIN
Universal Design, Inc.

Manchester Split-top Table Assembly Instructions

STEP 8] Attach Drawer support guide

Attach Drawer support guide (Part G) to base cross supports (part C & E) using 2 each 6x30mm Hex bolts. Tighten with Allen Wrench. See FIG 12.

PLEASE NOTE: Make sure the Drawer Support guide is facing the right as in FIG 12.

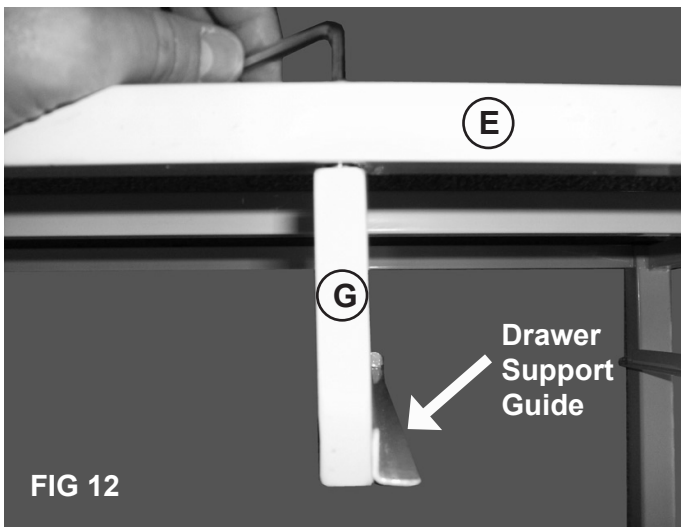

FIG 12

STEP 9] Attach Hinges to base

Attach 2 Hinges (Part M) to front edge Cross support (Part E) by lining up holes in hinge and holes in cross support E using 3 each 4x12mm screws (Part S) per hinge. Tighten with phillips screwdriver. SEE FIG 13.

PLEASE NOTE: Make sure that the Hinge is positioned as in FIG 13B

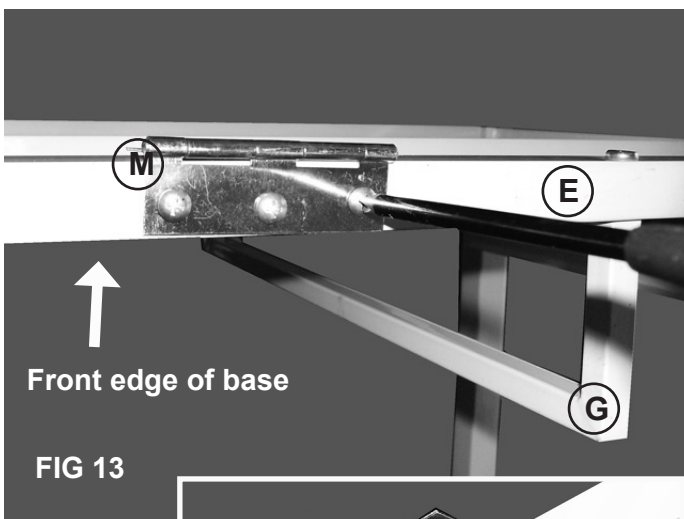

FIG 13

Hinges need to be attached as shown at right.



FIG 13B

STEP 10] Attaching Base to Top

Align holes in hinges to holes in top and align holes in tilt mechanism (Part J) to threaded holes in top. See FIG 14

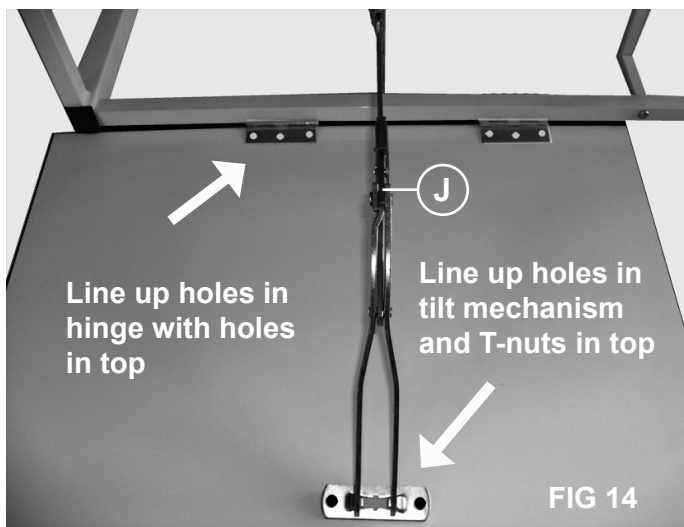
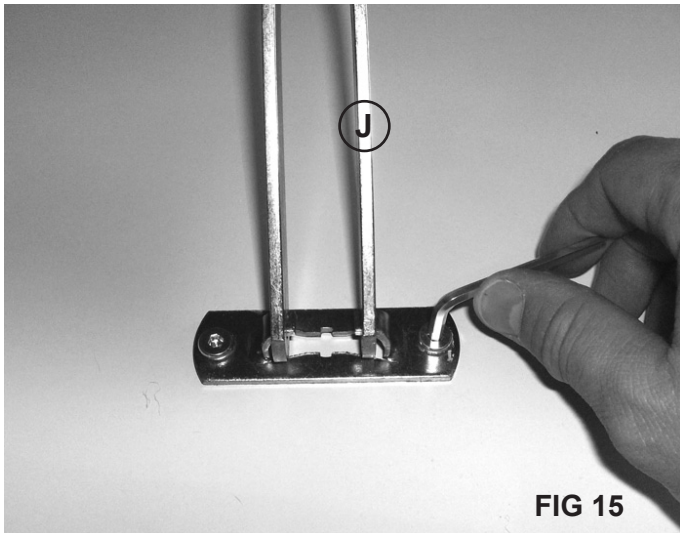

FIG 14

Manchester Split-top Table Assembly Instructions



STEP 11] Attach Tilt Mechanism to Top

After lining up holes, attach tilt mechanism (Part J) to top with 2 each 6x8mm Hex Bolts (Part P). Tighten with Allen Wrench. See FIG 15.

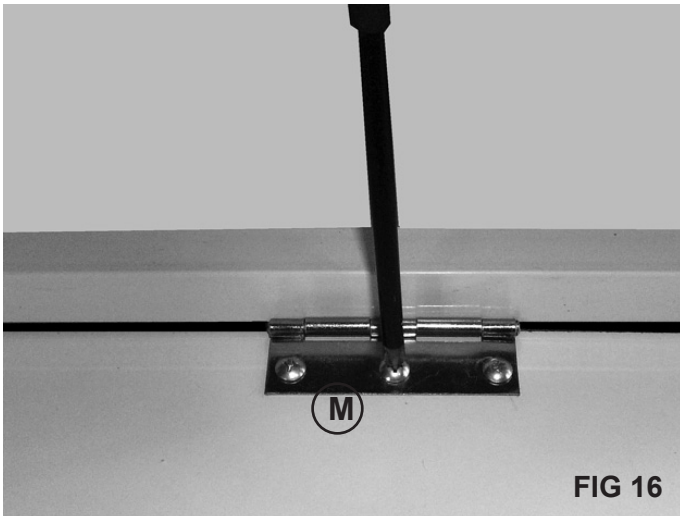

STEP 12] Attach Hinges to Top

Attach the 2 Hinges (Part M) to the top by using 3 each 4x12mm screws (Part S) per hinge. Tighten with phillips screwdriver. See FIG 16.

WARNING:

Turn table upright with **TWO PEOPLE** - DO NOT ATTEMPT to turn assembled table onto its legs with only one person. Then continue with assembly

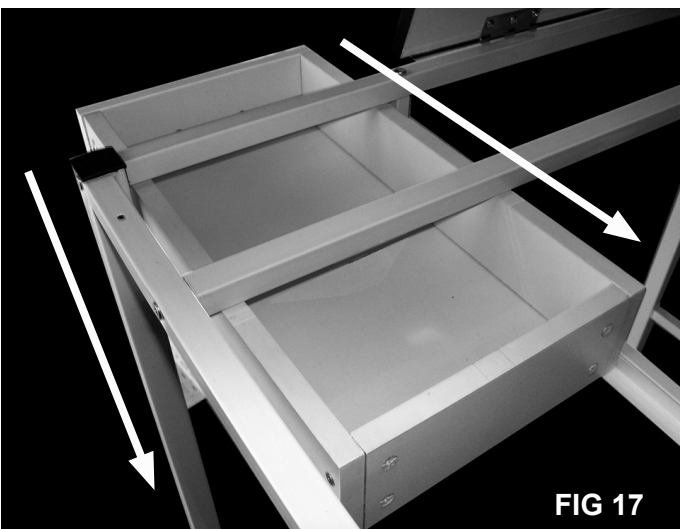

STEP 13] Attach Drawer Stop

PLEASE NOTE:

Before attaching Drawer Stop (Part X), the Drawer must be installed **FIRST!**

To do so, slide drawer onto drawer glides
See FIG 17.

FIG 17

Manchester Split-top Table Assembly Instructions

STEP 14] Attaching Drawer Stop, cont'd

After sliding Drawer into table, you need to install the drawer stop (Part X). This can be a bit tricky. You need to position the Drawer Stop (Part X) as shown in FIG 18 and FIG 18b, then from underneath, secure the drawer stop with a 6x8mm Hex Bolt (Part P). Tighten with the allen wrench.

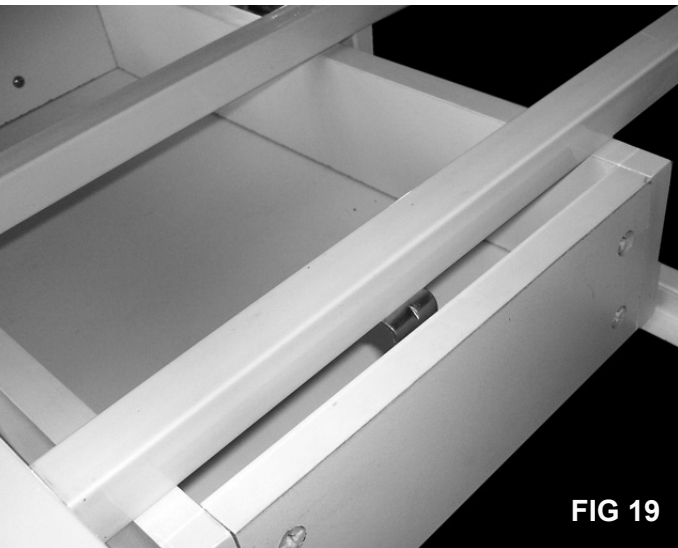
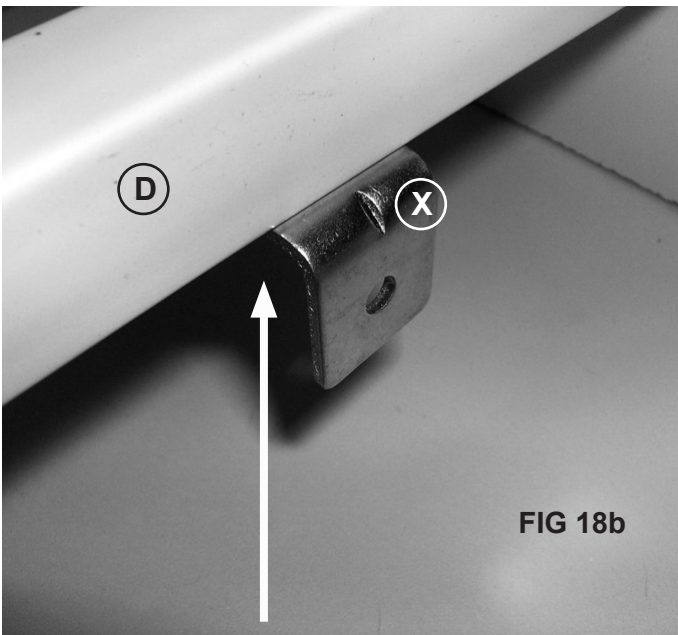
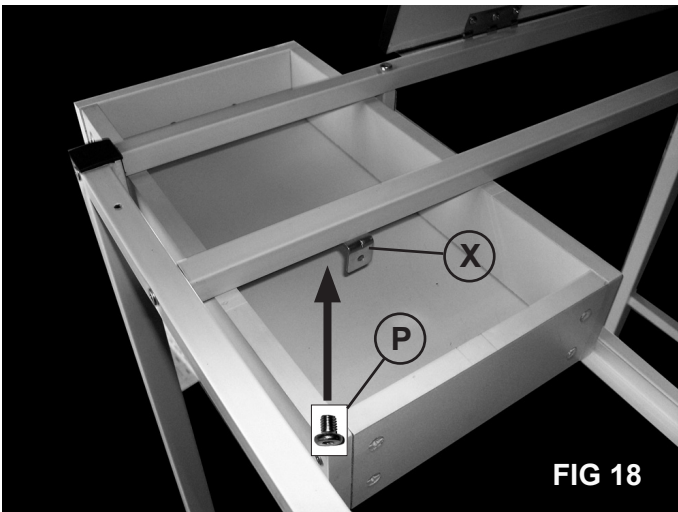

If installed correctly, the Drawer will not be able to be pulled all the way out of the table.

See FIG 19.

Manchester Split-top Table Assembly Instructions

WARNING:

To Install the SIDE SHELF, the Table must be turned back over onto its Table Top. Use 2 People to turn Table over onto the Table Top, making sure it is placed on a protected surface like a carpeted floor.

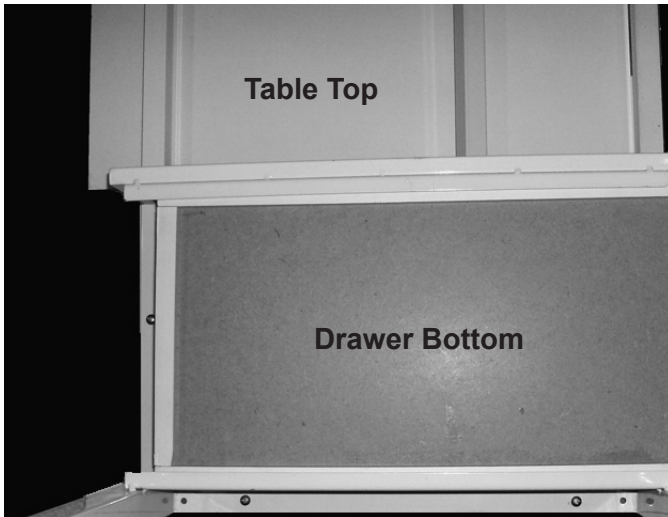

STEP 15] Attaching Side Shelf

NOTE: The photo at the left show the table laying top down on the carpeted floor and standing above the table looking downward.

Slightly lift the table up and slide the side shelf (Part H) underneath the drawer section, making sure to line up the Side shelf so that the edges are flush and even with the edge of the table top. See FIG 20

Continue with attachment of side shelf on next page.



▲ Line up the Side shelf so that the edge of the shelf is flush with the edge of the table top. Indicated by the white line.

Manchester Split-top Table Assembly Instructions

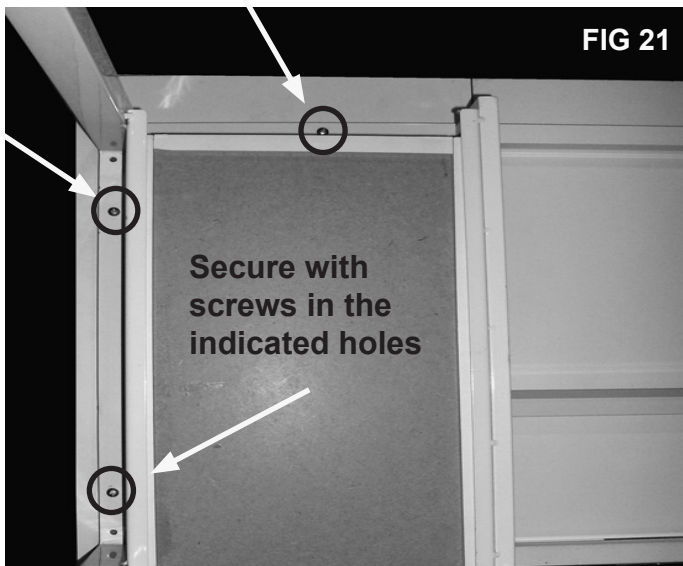

STEP 16] Attaching Side Shelf

Once Side Shelf is positioned correctly, secure shelf using 3 wood 4x30mm screws (Part R) in the holes indicated in FIG 21. Use a Phillips Screwdriver to secure.

DO NOT OVER TIGHTEN - This will cause the screws to be loose.

WARNING:

Your Table needs to be turned back onto its legs. Use 2 people to carefully turn the table back over onto its legs.



STEP 17] Attaching Pencil Ledge

Attach Pencil Ledge (Part W) to the front edge of table top, using 2 each 4x12mm screws (Part S) as shown in FIG 22.

Side view of pencil ledge after properly installed on table top

Proper Assembled Table should now look like Photo at Right.

To Tilt Table Top, lift on back edge of table top, from flat position and lift until desired position.

