

Kids' Dual Art Center Assembly Instructions

Model # U9102

Parts List

- A) 1 ea. Black Tray
- B) 1 ea. Wooden Dowel Rod
- D) 1 ea. Paper Roll - not pictured
- E) 4 ea. Bottom Legs
- F) 4 ea. 3/16" x 2" Bolts
- G) 4 ea. 3/16" x 2 1/2" Bolt
- H) 8 ea. 3/16" Flat Washer
- I) 8 ea. 3/16" Wing Nut
- J) 2 ea. Brackets
- K) 4 ea. 5/8" Phillip Head Screws
- L) 1 ea. Upper Easel Assembly



(A) Black Tray
1 each



(B) Wooden Dowel Rod
1 each

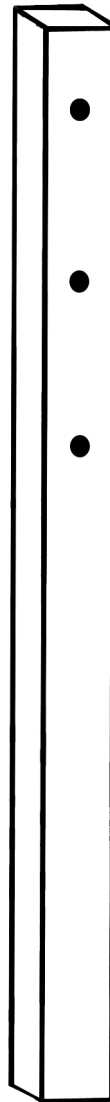

(E) Bottom Legs
4 each



(F) 3/16" x 2" Bolts
4 each



(G) 3/16" x 2-1/2" Bolts
4 each



(H) 3/16" Flat Washer
8 each



(I) 3/16" Wing Nut
8 each



(J) Bracket
2 each



(K) 5/8" Phillip Head Screws
4 each

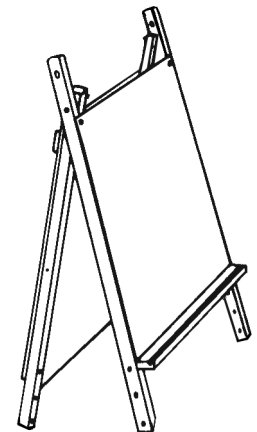

(L) Upper Easel Assembly
1 each

PLEASE NOTE:

All holes drilled to close tolerances for maximum rigidity. It may be necessary to tap bolts in place with a hammer.

PERIODIC RE-TIGHTENING WILL ASSURE A STURDY PRODUCT.

IMPORTANT!

If you have any difficulty assembling your Kids' Dual Art Centers or need customer service assistance, Please call: Martin Universal Design, Inc. Customer Service Hot Line at **(313)895-0700**. If you need additional parts, it is not necessary to contact your dealer, our Customer Service Rep. will forward them to you immediately.

Made in China



WARNING:
CHOKING HAZARD - small parts
Not for children under 6 years

Kids' Dual Art Center Assembly Instructions

Model # U9102

Enclosed are all the components necessary to assemble your new Deluxe Kids' Dual Art Center #U-9102. Prior to assembly make sure all your parts are enclosed by checking them against the parts list. Tools needed to assemble are a Phillips Screwdriver and a Hammer.

TO ASSEMBLE:

1. Attach 2 bottom legs (E) to green chalkboard side of upper easel assembly (L), using 4 ea. 3/16" x 2" bolts (F) and tighten with washers (H) and wing nuts (I). **See FIG 1.**

NOTE: Make sure the same hole is used on each leg for proper height. i.e. if you use the middle hole on one leg use the middle hole on all legs.

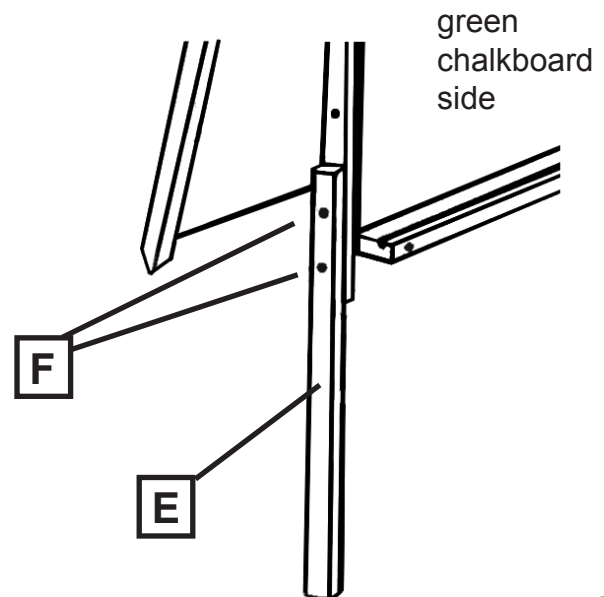

FIG 1.

2. Attach 2 bottom legs (E) to white board side of upper easel assembly (L), using 2 ea. 3/16" x 2 1/2" bolts (G), insert these bolts into holes near bottom of white board, tighten with washers (H) and wing nuts (I). **See FIG 1B.**

NOTE: Make sure the same hole is used on each leg for proper height. i.e. if you use the middle hole on one leg use the middle hole on all legs.

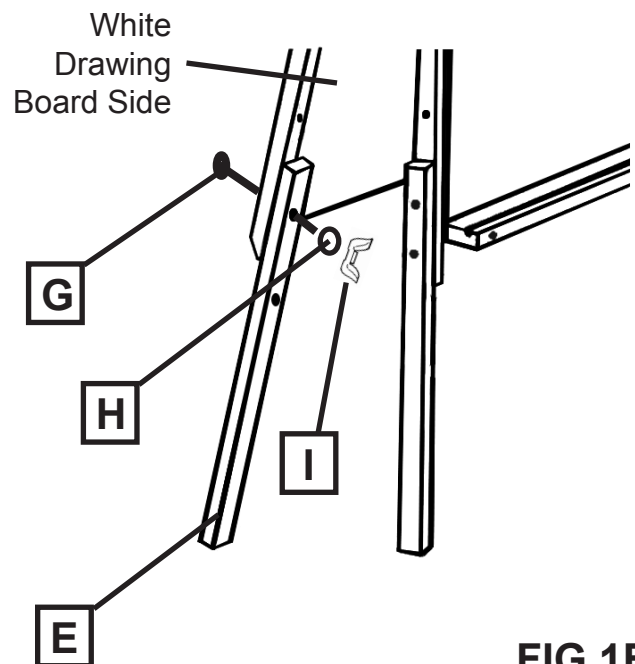
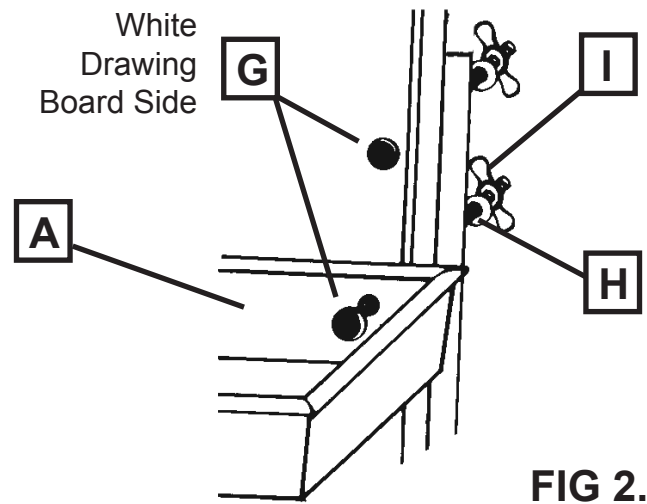

FIG 1B.

Kids' Dual Art Center Assembly Instructions

Model # U9102

3. Attach plastic tray (A) to white board side, using 2 ea. 3/16" x 2 1/2" bolts (G) into holes below white board, first insert bolt through black plastic tray, then through upper and lower leg and then attach washer (H) onto bolt and tighten wing nut (I). Repeat with other side.
See FIG 2.



4. Attach brackets (J) to both sides of easel using 4 ea. 5/8" phillip head screws (K) into pre-drilled holes and tighten.
Note: 2 screws per bracket.
See FIG 3.

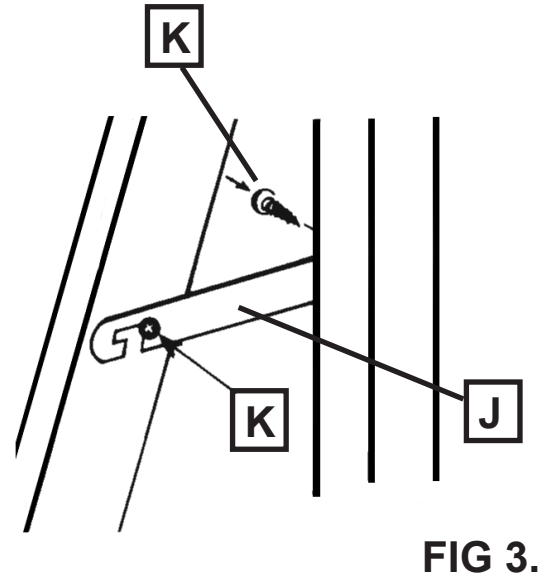

5. Insert dowel rod (B) through paper roll (D), then insert dowel rod through top of easel holes in easel side frame. **See FIG 4.**

FIG 4.

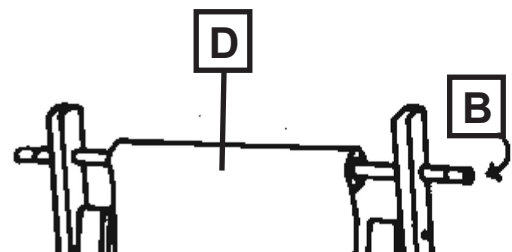

See FIG 5 on last page for exploded large view with part identification & completed easel illustrations.

Your child is now ready for hours of Creative Enjoyment!

Kids' Dual Art Center Assembly Instructions

Model # U9102

Complete easel with part identification FIG 5.

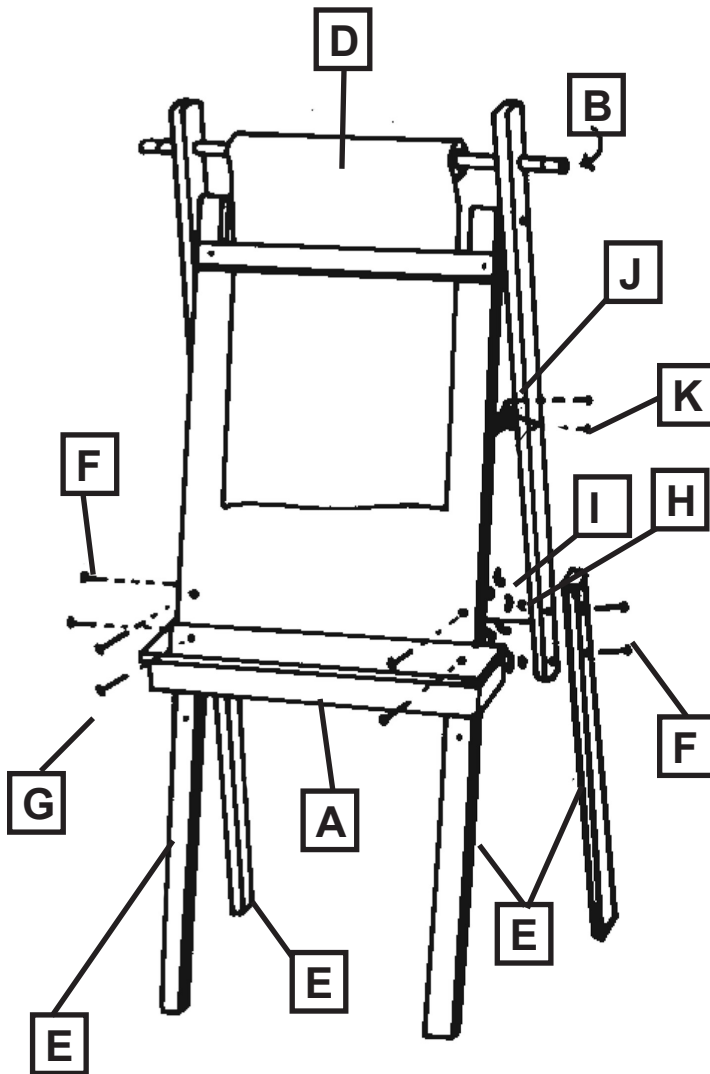

FIG 5.

Complete easel illustration. FIG 6.

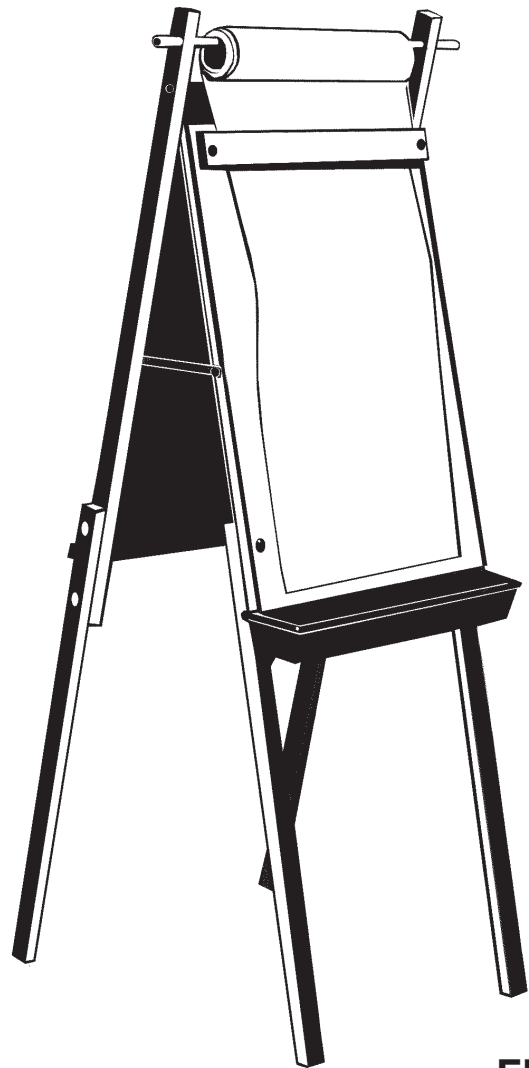

FIG 6.

WARNING:
CHOKING HAZARD - small parts
 Not for children under 6 years

IMPORTANT!

If you have any difficulty assembling your Kids' Dual Art Centers or need customer service assistance, Please call: Martin Universal Design, Inc. Customer Service Hot Line at **(313)895-0700**. If you need additional parts, it is not necessary to contact your dealer, our Customer Service Rep. will forward them to you immediately.