











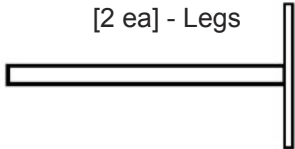





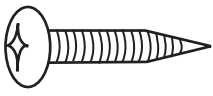

U-DS40 SMART TABLE • Assembly Instructions

Parts List

<p>[1 ea] - 24" x 36" Top</p>  <p>A</p>	<p>[2 ea] - Top & Base Supports</p>  <p>B</p>	<p>[2 ea] - Legs</p>  <p>C</p>
<p>[1 ea] - Base Cross Support</p>  <p>D</p>	<p>[4 ea] - Feet</p>  <p>E</p>	<p>[2 ea] - Upper Legs</p>  <p>F</p>
<p>[2 ea] - Collars</p>  <p>G</p>	<p>[2 ea] - Tilt Arms</p>  <p>H</p>	<p>[1 ea] - Pencil Edge</p>  <p>I</p>
<p>[2 ea] - Knobs</p>  <p>J</p>	<p>[8 ea] - Screws (6x25mm)</p>  <p>K</p>	<p>[6 ea] - Allen Bolts (6x40mm)</p>  <p>L</p>
<p>[2 ea] - Allen Bolts (6x12mm)</p>  <p>M</p>	<p>[2 ea] - Screws</p>  <p>N</p>	<p>[4 ea] - Nuts</p>  <p>O</p>
<p>[4 ea] - Small Washer</p>  <p>P1</p>	<p>[2 ea] - Large Washer</p>  <p>P2</p>	<p>[1 ea] - Wrench</p>  <p>Q</p>
<p>[1 ea] - Allen Wrench</p>  <p>R</p>		

IMPORTANT

If you have difficulty assembling your U-DS40 Smart Table or need customer service assistance. Please call: Martin Universal Design, Inc. Customer Service Hot Line at 1-313-895-0700. If you need additional parts, it is not necessary to contact your dealer, our Customer Service Rep. will forward them to you immediately.

NOTE: READ ALL ASSEMBLY INSTRUCTIONS FIRST
BEFORE ATTEMPTING TO ASSEMBLE U-DS40 SMART TABLE.

- TWO PEOPLE NEEDED FOR TABLE ASSEMBLY -

U-DS40 SMART TABLE • Assembly Instructions

FIG 1

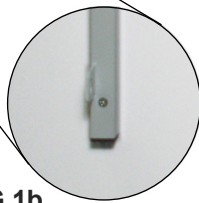
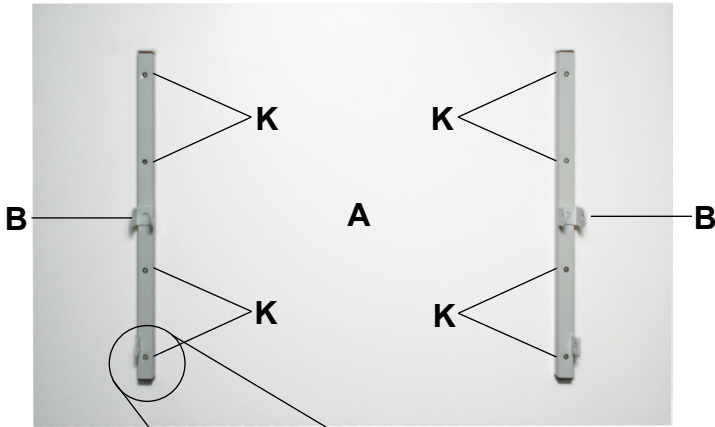

Make sure the base supports are positioned so that the tab is on the outer side of the base support. See image to the left FIG 1b.

FIG 1b

STEP 1] Attach Base supports to Top

IMPORTANT:
ASSEMBLE TABLE ON FLAT CARPETED SURFACE TO PROTECT TOP FROM MARRING

Begin by taking your table top (part A) and lay it face down onto your flat carpeted work surface (holes facing up). Take [2 each] Base Supports (part B) and position them so that they line up with the holes in the top and metal tab is positioned on the outer side of the base support.

See FIG 1b.

Using [4 each] 6x25mm Screws (part K) per base support. Secure by tightening these screws to secure base support to top. Repeat with second base support (part B).

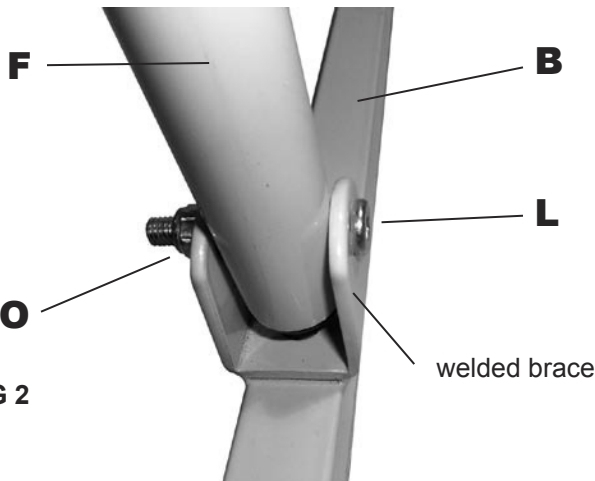

FIG 2

STEP 2] Attach Upper Legs

To attach the upper legs (part F) to the base supports (part B), line up the hole found in the upper leg with the welded brace found on the base support. Line up the holes, insert a 6x40mm Allen Bolt through the welded brace then through the upper leg and then through the other side of the welded brace add a nut (part O). Tighten to secure.

See FIG 2 & 2b.

Repeat with second upper leg.

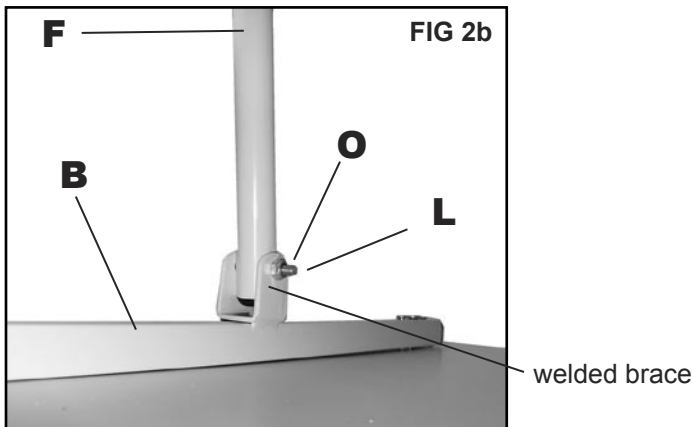
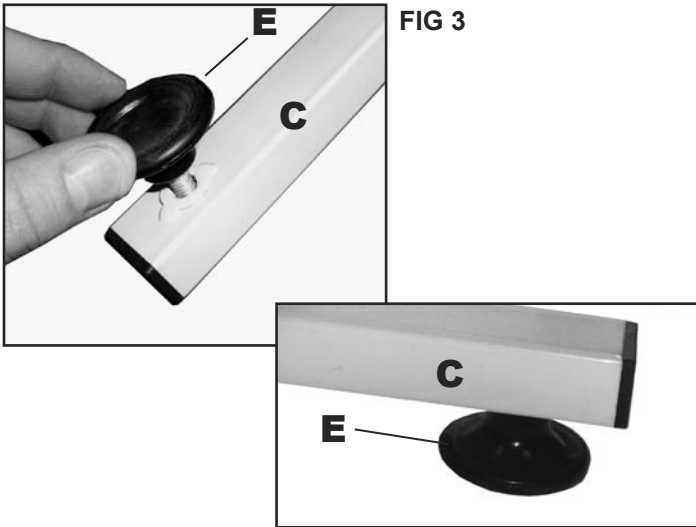

FIG 2b

U-DS40 SMART TABLE • Assembly Instructions



STEP 3] Attach Adjustable Rubber Feet

Attach the [4] adjustable rubber feet (part E) to Legs (part C) by threading the rubber feet clockwise into the bottom holes of the legs. See Fig 3 images.

NOTE: To adjust the level of the base once assembled, unscrew or tighten each rubber foot until table is level.

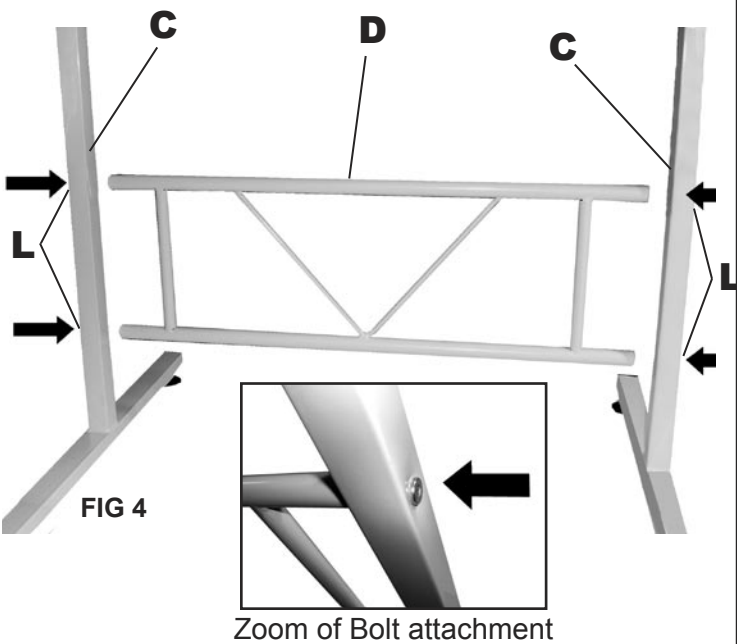

STEP 4] Base Assembly

Take the [2] legs (part C) that have the rubber feet attached and the [1] Base cross support (part D). Attach the base support (part D) to each leg using [2 each] 6x40mm Allen bolts (part L) to each leg. Line up holes in the legs to the ends of the base support. Insert bolt through outer side of legs and into holes on end of base Support.

Tighten bolts with Allen Wrench.
See FIG 4

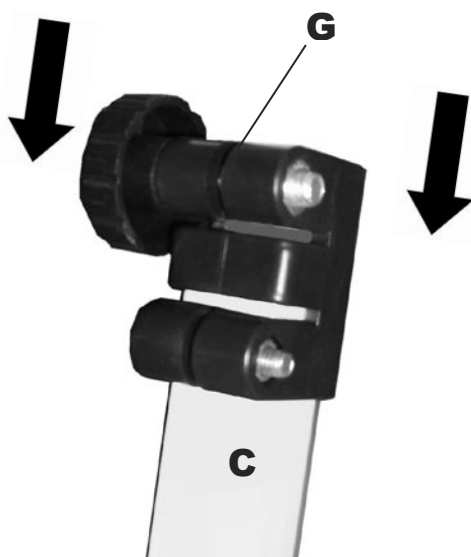

STEP 5] Attach Collars to Base Legs

Attach the [2 each] Collars (part G) to the top ends of the legs as shown in the picture in FIG 5.

Make sure the knob is positioned on the outer side of the legs.

NOTE: Loosen the knob on the collar (part G) prior to sliding the collar down over the legs (part C).

FIG 5

U-DS40 SMART TABLE • Assembly Instructions

STEP 5] Attach Top to Base

IMPORTANT: USE TWO PEOPLE FOR THIS STEP

Loosen knobs on collars (part G) to allow the upper legs to be inserted into the collars easier.

Have each person hold onto the table top and guide the [2] upper legs (part F) into the collars that are attached to the base assembly. Tighten knobs on collars to secure.

SEE FIG 6.

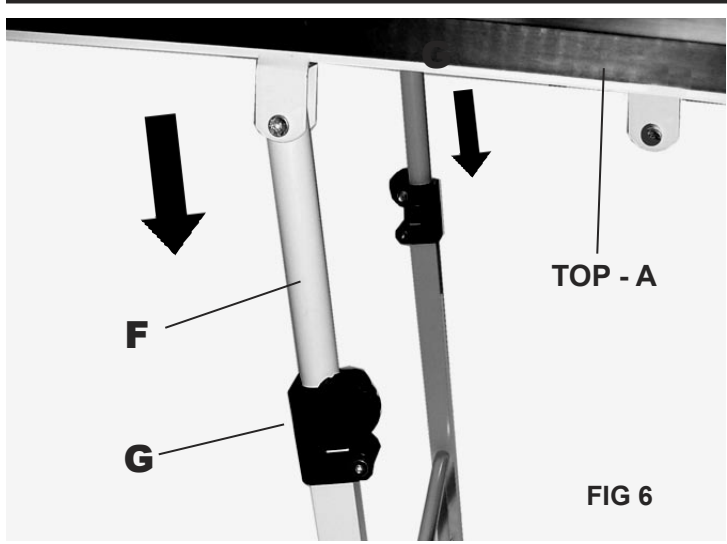

STEP 7] Attach [2] Tilt Arms to Table

You need the [2] Knobs (part J), [2] Tilt Arms (part H), and [2] Large Washers (part P2) to attach Tilt Arms to table.

Insert the bolt that is connected to the Knobs (part J) through the tilt arm (use the end that is opposite the hole) add the large washer (part P2) to the knob bolt and then thread into the table legs.

Repeat with opposite side. SEE FIG 7.

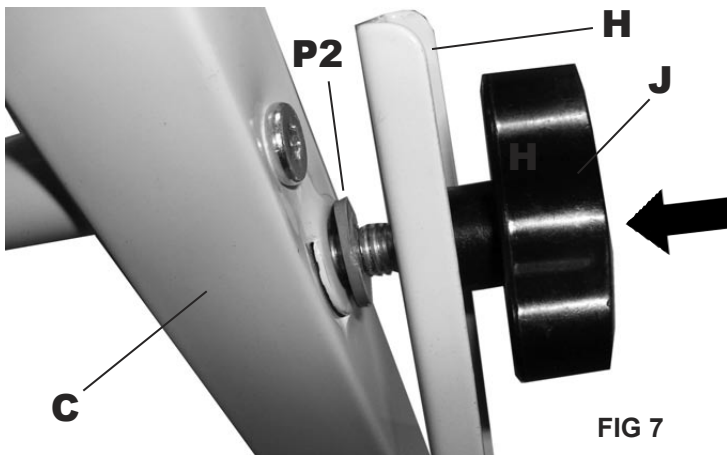

NOTE: These are the Knobs that you will loosen to adjust the tilt of the table.

STEP 8] Attach [2] Tilt Arms to Top

To attach the Tilt Arm (part H) to the Top Support (part B), you will need to insert the 6x12mm allen bolt (part M) with a small washer (part P1) through the tilt arm, then through the top support tab. Continue by adding another washer (part P1) to the end of the bolt and finish by adding a nut (part O). Tighten with wrench (part Q) to secure. Repeat with other Tilt Support.

SEE FIG 8.

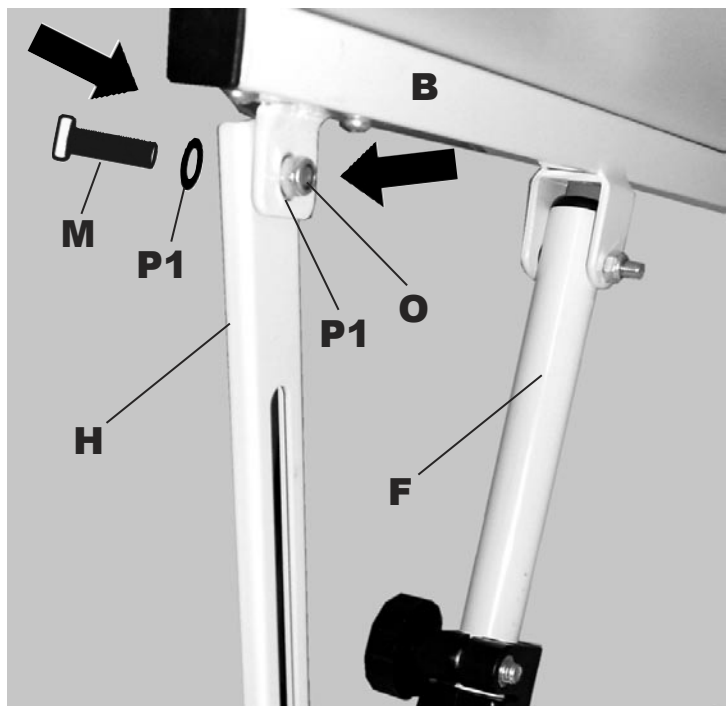

U-DS40 SMART TABLE • Assembly Instructions



FIG 9

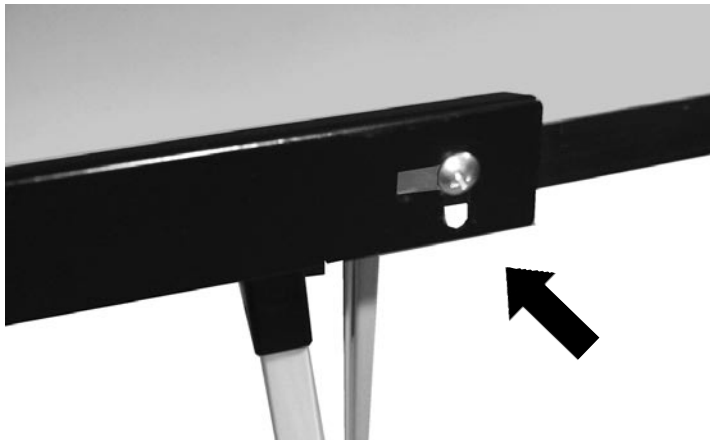

FIG 9B - ZOOM of Pencil Ledge attachment

STEP 9] Attach Pencil Ledge

Attach Pencil Ledge (part I) to the front edge of the Top using [2] Screws (part N). Tighten to secure.

NOTE: Slightly loosen screw to allow for raising or lowering of pencil ledge.

SEE FIG 9 & FIG 9B

Once complete, double check all screws and bolts to make sure they are secure.
Enjoy Your New SMART TABLE!

STEP 10] Tighten All Screws and Bolts

HEIGHT ADJUSTMENT:

To adjust the height of your table - loosen the knobs on the collars found on the base of the table and lift the table top to desired height.

TILT ADJUSTMENT:

To adjust the tilt of your table top, loosen the knobs on the side of the legs and hold onto table top and tilt to desired angle. Tighten knobs on legs to secure.

LEVELING FLOOR GUIDES:

If your floor is uneven, you can adjust the floor guides by loosening the floor guides to make up for the uneven floor.