



Ariel Table Assembly Instructions

Model No. U-HL6080W



UPC 080031055002











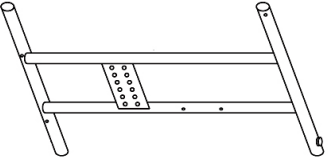
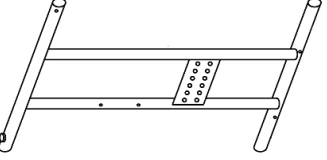
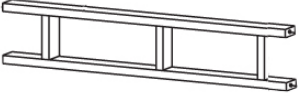

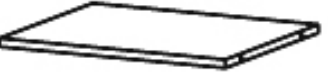







IMPORTANT

If you have difficulty assembling your Ariel Table - MODEL # U-HL6080W
or need customer service assistance. Please call:
Martin Universal Design, Inc. Customer Service Hot Line at 1-313-895-0700.
If you need additional parts, it is not necessary to contact your dealer,
our Customer Service Rep. will forward them to you immediately.

MARTIN
Universal Design, Inc.

Martin Universal Design, Inc. • Detroit, MI 48208 USA
Tel: 1-313-895-0700 • E-mail: custservmud@gmail.com
www.MartinUniversalDesign.com • Made in China

Ariel Table Hardware Parts List

<p>Part A. 1 ea. Left Leg</p> 	<p>Part B. 1 ea. Right Leg</p> 	<p>Part C. 1 ea. Cross Support</p> 	<p>Part D. 1 ea. Ruler Support Bar</p> 
<p>Part E. 1 ea. Base Shelf</p> 	<p>Part F. 1 ea. Table Top</p> 	<p>Part G. 1 ea. Ruler</p> 	<p>Part H. 1 ea. Tilt Mechanism</p> 
<p>Part I. 2 ea. Side Tray A</p> 	<p>Part J. 2 ea. Side Tray B</p> 	<p>Part K. 2 ea. Castors</p> 	<p>Part L. 2 ea. Locking Castors</p> 
<p>Part M. 4 ea. CAM Locks</p> 	<p>Part N. 2 ea. Plastic Caps</p> 	<p>Part O. 8 ea. Side Tray Clips</p> 	<p>Part P. 2 ea. Top Brackets</p> 
<p>Part Q. 8 ea. 6x55mm Hex</p> 	<p>Part R. 2 ea. 6x30mm Hex</p> 	<p>Part S. 2 ea. Nylon Nuts</p> 	<p>Part T. 22 ea. 5x14mm screws</p> 
<p>Part U. 3 ea. 4x35mm Hex</p> 	<p>Part V. 1 ea. Wrench</p> 	<p>Part W. 1 ea. Allen Wrench</p> 	

Ariel Table Assembly Instructions:

Step 1. Attach Castors to Left and Right Legs

Insert 1 ea. Locking Castor (Part L) into each of the two front holes found on the bottom of each leg (Part A & B)

Insert 1 ea. Castor (Part K) into each of the two rear holes found on the bottom of each leg (Part A & B)

See FIG 1

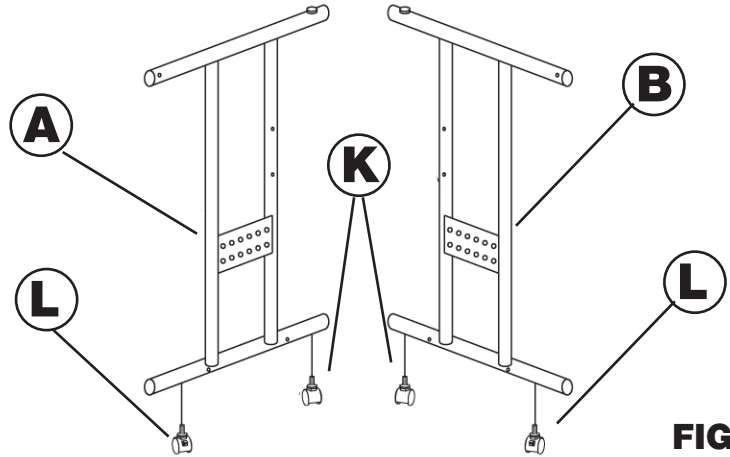

FIG 1

Step 2. Insert Cam Locks into Base Shelf

Insert 4 ea. Cam Locks (Part M) into each of the holes found on the bottom side of the Base Shelf (Part E), making sure holes line up with holes in shelf edge.

See FIG 2

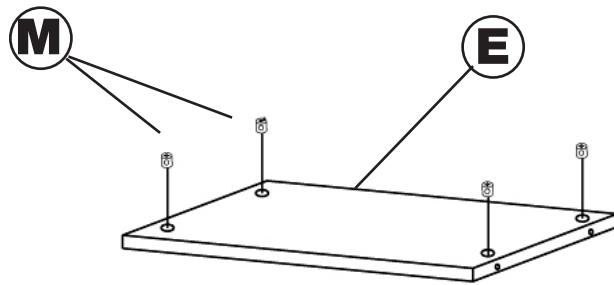

FIG 2

Step 3. Attach Cross Member to ea. leg.

Attach Cross Member (Part C) to each leg using 2 each Hex Bolts (Part Q). Thread the Hex bolt through the side of each leg and into the cross member holes.

DO NOT TIGHTEN at this point, keep the bolts slightly loose.

See FIG 3

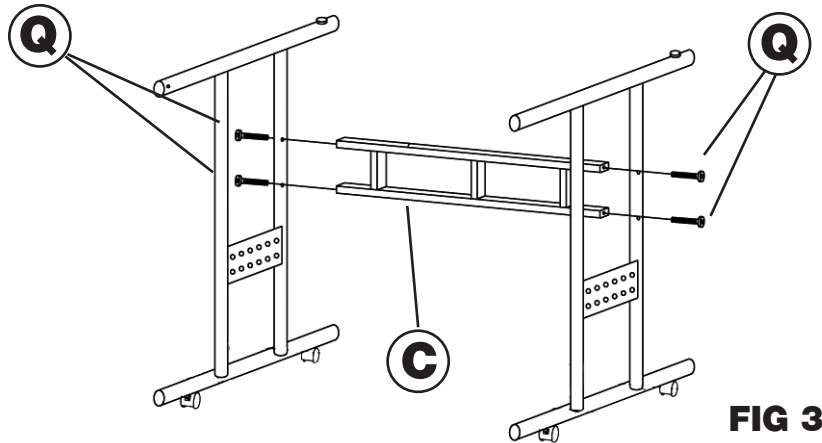

FIG 3

Step 3B. Attach Base Shelf to Base

Attach White Base Shelf (Part E) to base using 2 each Hex Bolts (Part Q) in each end of Shelf. **TIGHTEN** using Allen Wrench (Part W). Repeat with other side. See FIG 3B

NOW go back and **TIGHTEN CROSS MEMBER HEX BOLTS** (STEP 2) with Allen Wrench (Part W).

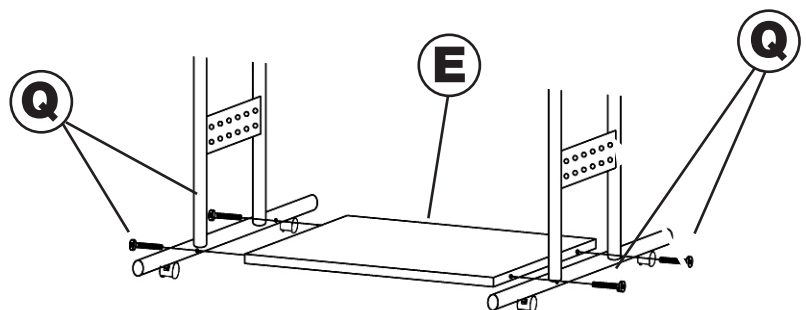

FIG 3B

Ariel Table Assembly Instructions:

Step 4. Attach Table Top Tilt Mechanism
 Attach Tilt Mechanism (part H) to Cross member (part C) in position as seen in FIG 4.

Secure by using 2 ea. Hex Bolts (part R) and 2 ea. Nylon Nuts (part S). Tighten to secure with supplied wrench (part W)

See FIG 4

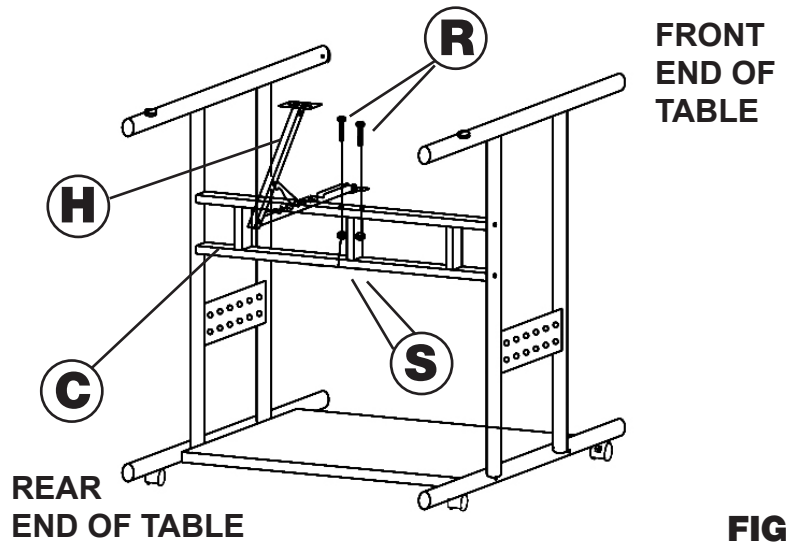

Step 5. Attach Ruler Support Bar

Begin by laying Table Top (part F) face down on protected hard floor (like a carpeted floor).

Attach Ruler Support Bar (part D) to bottom of table top by lining up Support Bar to the pre-drilled holes in the table top. Secure using 3 wood screws (part U). Insert 2 each plastic caps into the holes on either end of the ruler support bar.

See FIG 5.

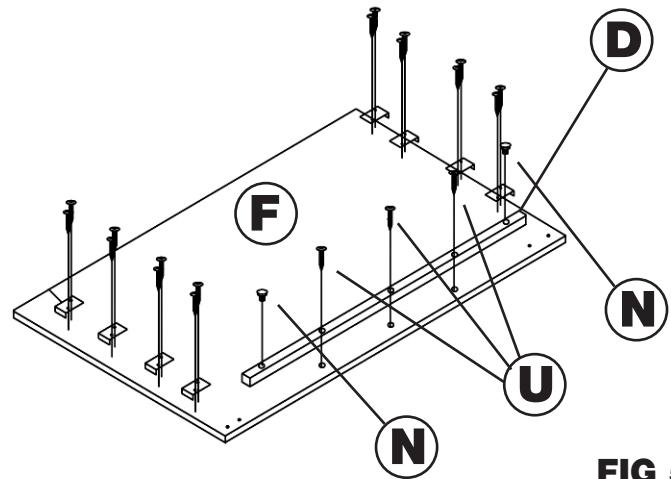

Step 5B. Attach Side Tray Metal Clips

Line up all 8 Metal Side Tray Clips (part O) to each hole in the top and secure each one to the table top using 2 ea. wood screws (part T) per metal support.

PLEASE NOTE: The lip on the Metal Side Tray Supports should wrap around the side edge of the table top.

See FIG 5B.

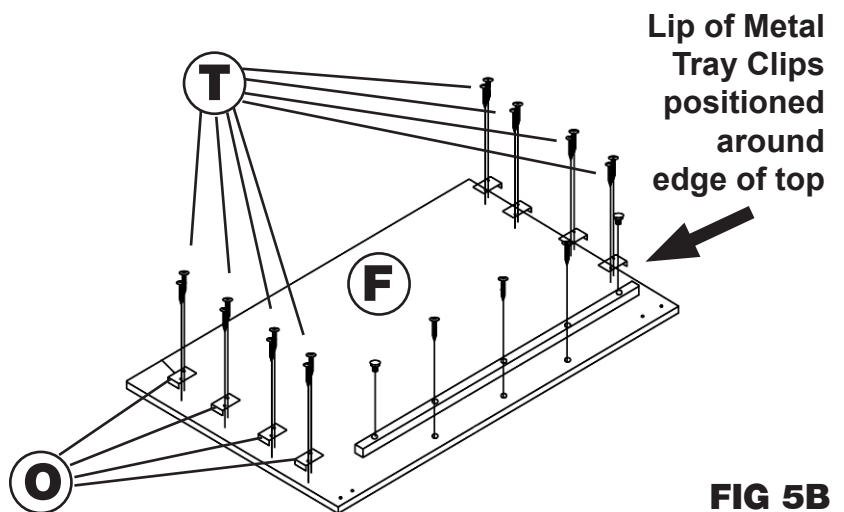

Ariel Table Assembly Instructions:

Step 6. Attach Ruler to Ruler Support Bar

Clip/Snap Ruler (part G) onto Ruler Support Bar (Part D).

See FIG 6.

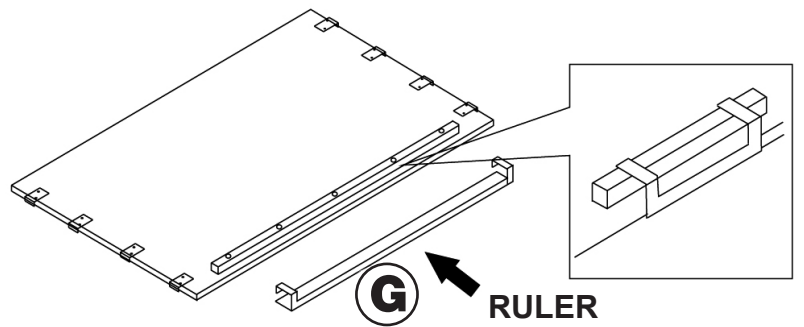

Step 7. Attach Table Top Brackets

Attach 1 ea. Table Top Brackets (part P) to each left & right leg by inserting bracket rod into hole found on inside edge of the legs top support bar.

See FIG 7.

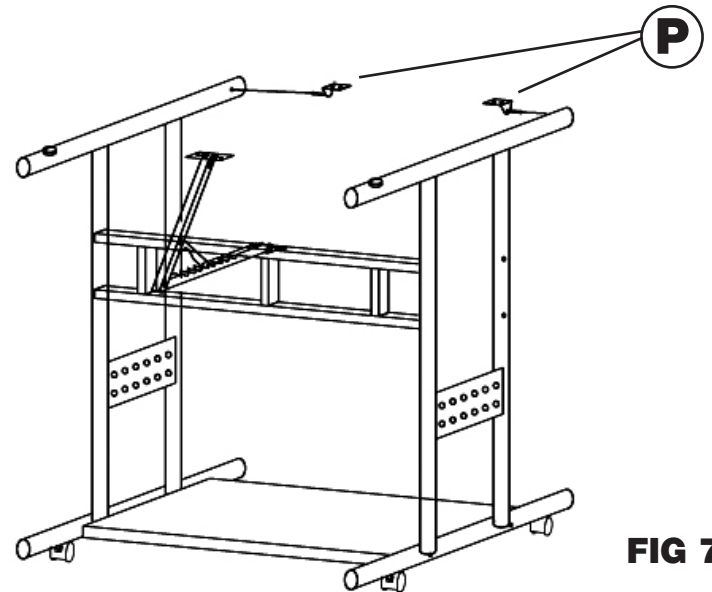

Step 8. Attach Table Top to Base Assembly

Line up holes in table top (part F) with Table Top Metal Brackets (part P) located on each leg's top support bar. Secure using 2 ea. Wood Screws (part T). Tighten to secure.

See FIG 8

Continue by attaching Tilt Mechanism (part H) to table top by lining up holes in tilt mechanism to holes in table top and securing with 2 ea. Wood screws (part T). Tighten to secure.

See FIG 8

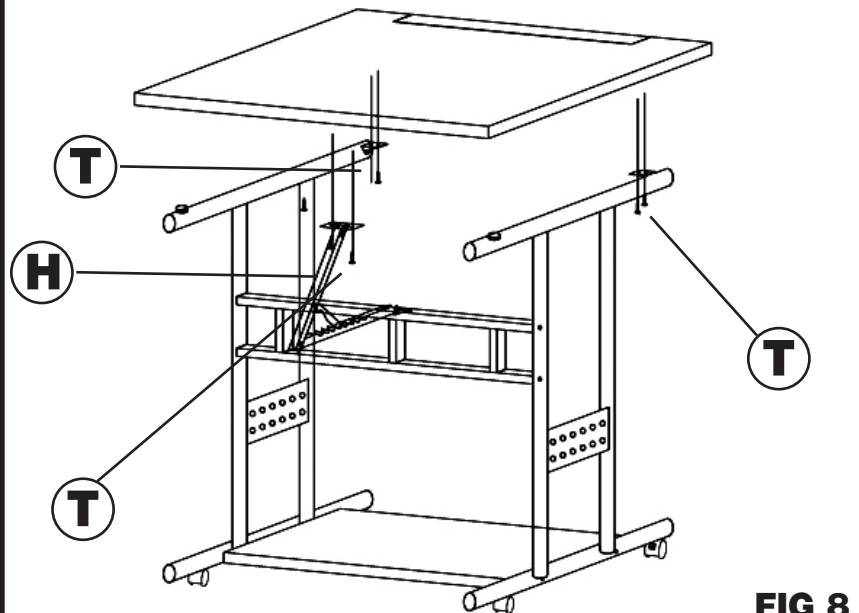

Ariel Table Assembly Instructions:

Step 9. Assembling 2 Side Trays into one long tray. (Optional)

If you would like one long side tray, you must clip 2 Side Trays (part I & J) together as shown in **FIG 9**.

OPTIONAL CHOICES:

If you would like to use two of the same Side Trays together you may. As shown in **FIG 9B** and **9C**

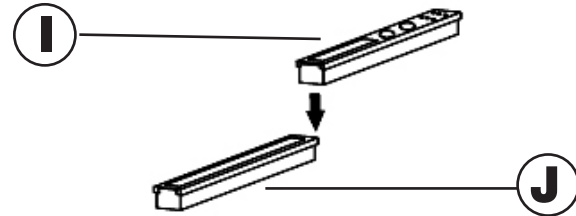

FIG 9

OR

OR

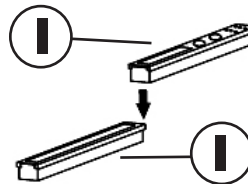

FIG 9B

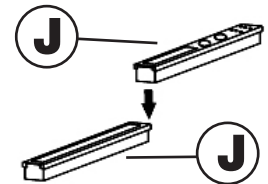

FIG 9C

Step 10. Attach Side Trays to Table Top

To attach the side trays (parts I & J) to the table top, slide the side trays down onto the brackets making sure the side tray edge fits onto the metal brackets. See **FIG 10**.

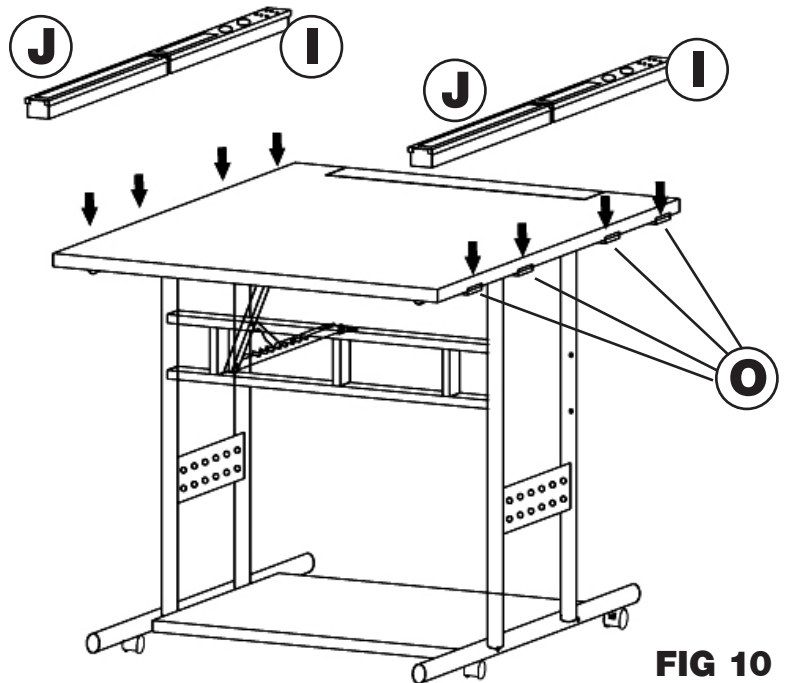

FIG 10

Step 11. COMPLETING ASSEMBLY

Go back and make sure all screws and bolts are tight, Once complete, your Ariel Table is now ready for your enjoyment!