



92-3010 • MONSTER AMALFI STUDIO EASEL ASSEMBLY/SET-UP INSTRUCTIONS

MAKE SURE CARTON CONTAINS THE FOLLOWING PARTS

WOOD PARTS

Quantity	Description	ID#
2 ea.....	Base Feet	[1]
2 ea.....	Base Cross Members	[2]
2 ea.....	Uprights	[3]
1 ea.....	Channelled Center Column	[4]
1 ea.....	Material Tray	[5]
2 ea.....	Channelled Side Columns	[6]
1 ea.....	Ratchet Column	[7]
1 ea.....	Lower Cross Member	[8]
1 ea.....	Upper Cross Member	[9]
2 ea.....	Extendable Rear Legs	[10 & 11]
1 ea.....	Adjustable Center Column	[12]
1 ea.....	Upper Canvas Support	[13]

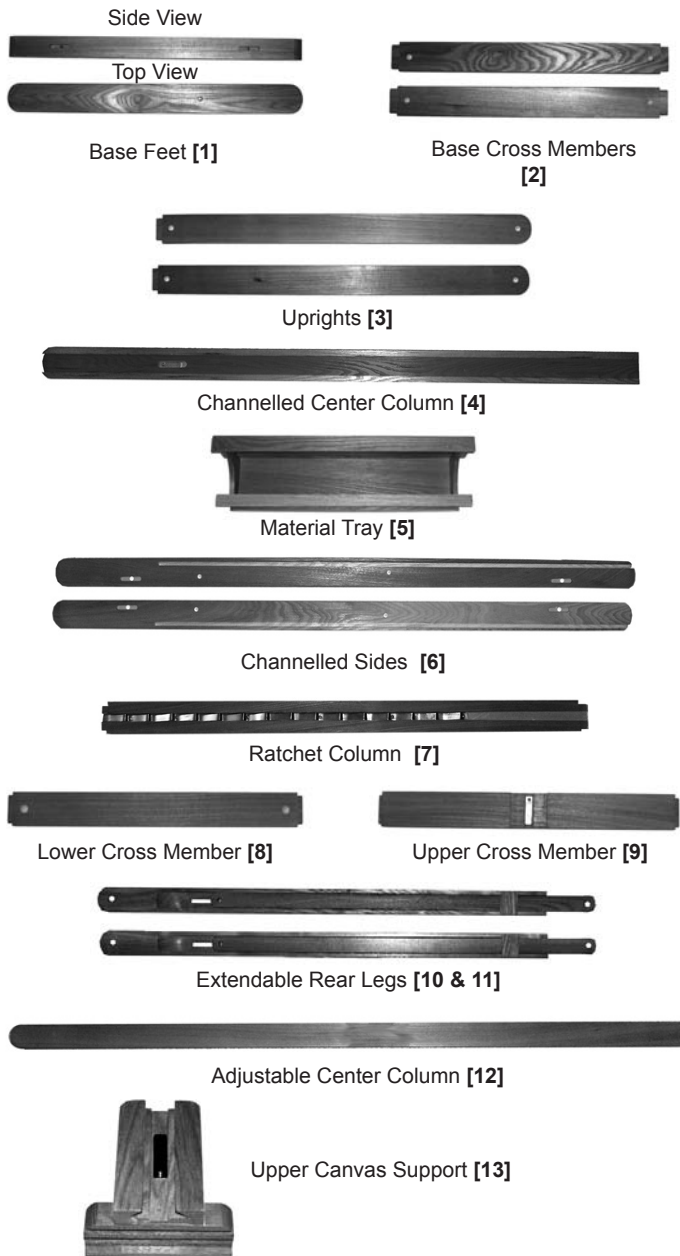

HARDWARE PARTS

Quantity	Description	ID#
4 ea...	Bolts & Cams: 6 X 60mm	[A]
16 ea. .	Screws: 4 X 16mm	[B]
2 ea...	Bolts & Cams: 6 X 60mm	[C]
4 ea. .	Screws: 4 X 25mm	[D]
1 ea...	Loop Mechanism & [4] Screws	[E]
4 ea...	Bolts & Cams: 6 X 60mm	[F]
2 ea...	6 X 70mm Bolt/Knob/Washer&Wood Washer	[G]
2 ea...	6 X 45mm Bolt/Knob & Washers	[H3]
2 ea...	6 X 40mm Bolt/Knob & Washers	[H4]
2 ea...	5 X 35mm Screws	[H5]
3 ea...	Knobs: 2 same size one longer	
4 ea...	Castors: 2 locking, 2 not locking	

TOOLS INCLUDED

Quantity	Description
1 ea.....	Flathead Screwdriver - Red Handle
1 ea.....	Phillips Head Screwdriver - Orange Handle



IMPORTANT - READ ALL INSTRUCTIONS BEFORE ASSEMBLING EASEL and USE 2 PEOPLE WHEN ASSEMBLING!

STEP 1. Attach the [4] castors to the two base feet (1) making sure the 2 locking castors are positioned in the rear. **NOTE:** the rear of the base has the hole nearest that castor position. Secure with four screws (B) per castor. See FIG 1.

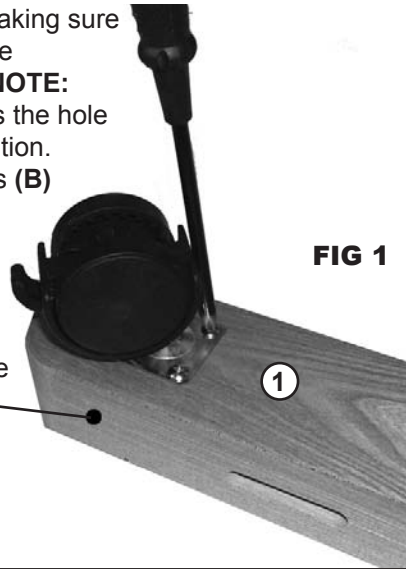

FIG 1

STEP 2. Attach the two Base Cross members (2) to the base feet (1) By inserting the oval male end of the Base Cross member into the oval female cut-out of the base foot. See Fig 2. **NOTE: The hole in the cross member should be up, since the base is upside down.** Repeat with second cross member.

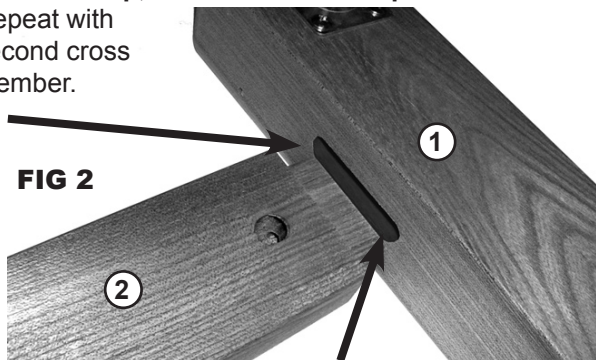

FIG 2

STEP 3. Secure Base Cross Members to base using the four 6 X 60mm Bolts and Cams (A). Insert Cam into hole found in Base Cross Member and insert bolt into base foot. Tighten by holding Cam in position while tightening down bolt with phillips screwdriver. See FIG 3.

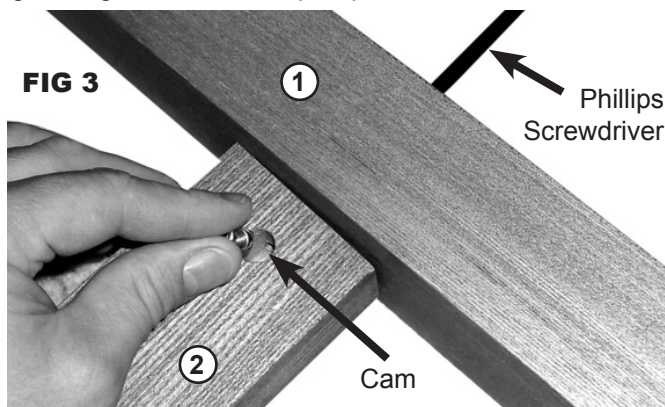

FIG 3

STEP 4. Turn your base assembly over onto the castors and you should now have a base that is assembled like FIG 4.

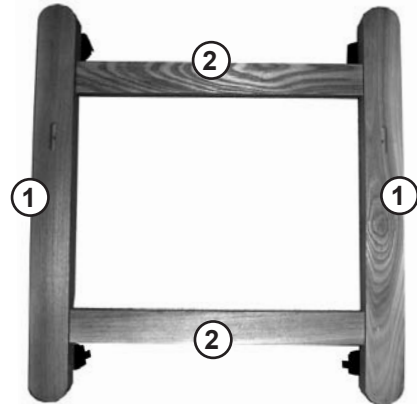

FIG 4

STEP 5. This next step involves attaching the uprights (3) to the base assembly. You will find two oval holes on the top side of the assembled base, these oval holes are for the oval male ends of the uprights (3) to go into. Secure with two 6 x 60mm bolts and cams (C).

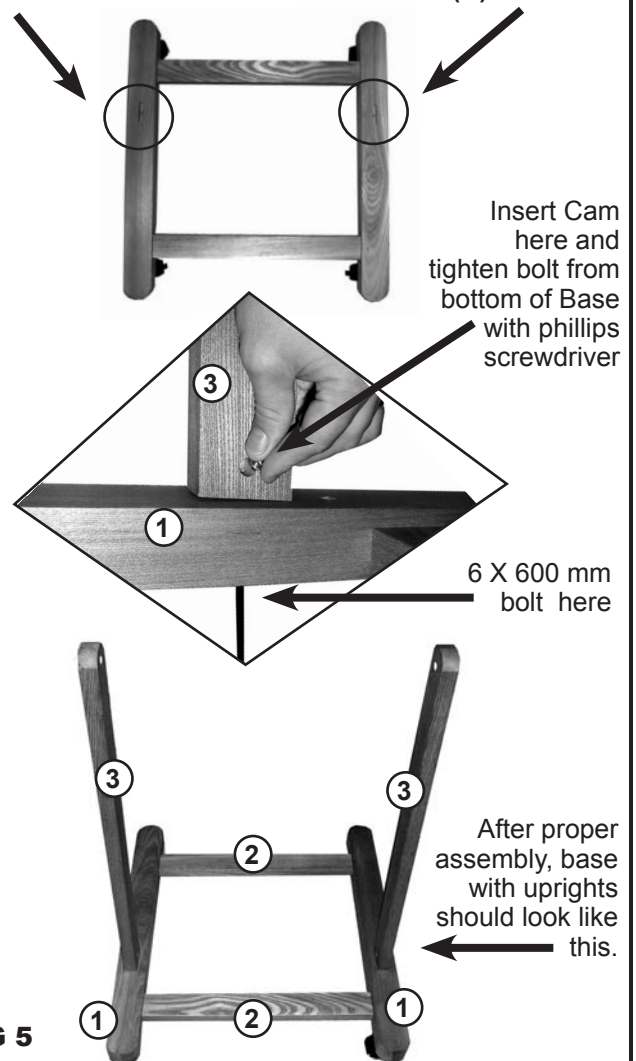

FIG 5

Insert Cam here and tighten bolt from bottom of Base with phillips screwdriver

6 X 600 mm bolt here

After proper assembly, base with uprights should look like this.

STEP 6. Attach Material Tray (5) to Channelled Center Column (4) using four 4 X 25mm Screws (D). See FIG 6a & FIG 6b.

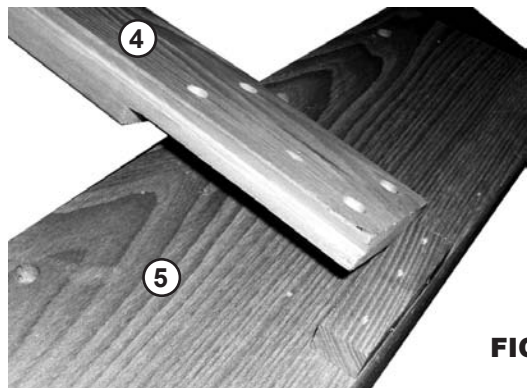

FIG 6a

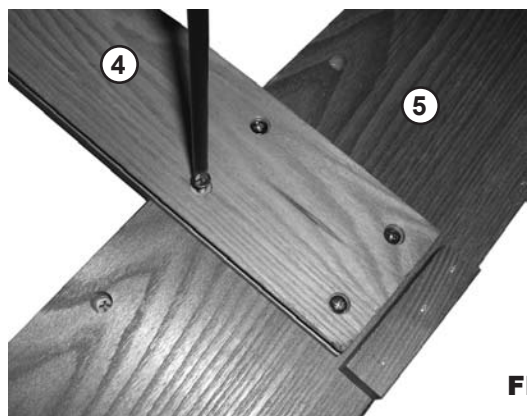

FIG 6b

STEP 7. Attach Loop Mechanism (E) to Material Tray (5) using the four 3 X 12mm screws. Secure with Phillips Screwdriver (provided) See FIG 7.

NOTE: Make sure the Loop Mechanism is in the proper position as shown in FIG 7. This will allow for proper adjustments when moving the material tray up or down the Ratchet Column.

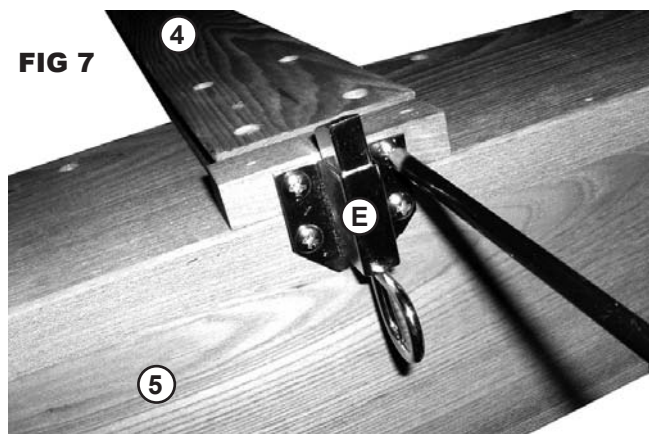

FIG 7

STEP 8a. Assembling the H-Frame. This step involves assembling parts (6, 7, 8 & 9) to form the H-Frame portion of the easel. Begin by taking the channelled sides (6) & the upper cross member (9) and inserting the oval male ends of the upper cross member into the oval holes of the channelled sides. See FIG 8a. Secure this step using two 6 X 60mm bolts and Cams as previously described in earlier steps. (as in Step 3)

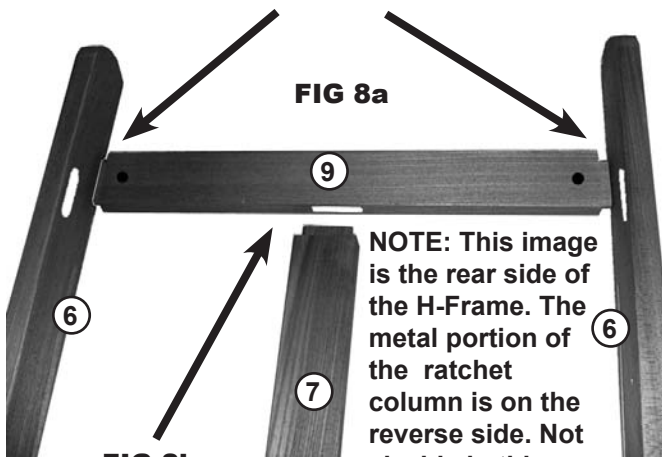
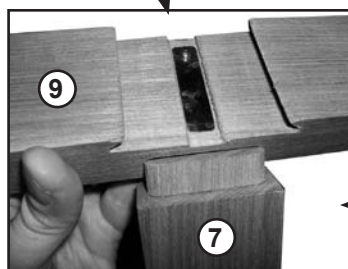

FIG 8a

NOTE: This image is the rear side of the H-Frame. The metal portion of the ratchet column is on the reverse side. Not visible in this photo.

FIG 8b



STEP 8b. Continue by inserting the ratchet column (7) up into the oval hole of the upper cross member (9).

Make sure the Ratchet column is positioned so that the metal part that is closest to one end of the column is the bottom end. See FIG 8c.

NOTE: This column is secure once the bottom portion of the H-Frame is assembled.



Top Portion of Ratchet Column connects with upper cross member (9)

Bottom End of Ratchet Column connects with lower cross member (8)

FIG 8c

STEP 10. Finish assembling the H-Frame by attaching the lower cross member (8) to the ratchet column (7) by inserting the ratchet column down into the oval hole of the lower cross member. Secure by fitting the lower cross member into the oval holes of the channelled sides (6). See FIG 10. Secure this step, using two 6 X 60mm bolts and Cams as previously described in earlier steps. (as in Step 3)

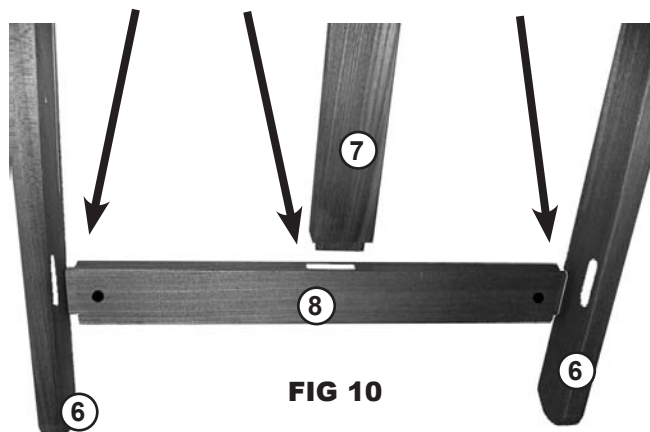

FIG 10

STEP 11. Your assembled H-Frame should look like FIG 11.

NOTE: This is the front view of the assembled H-Frame

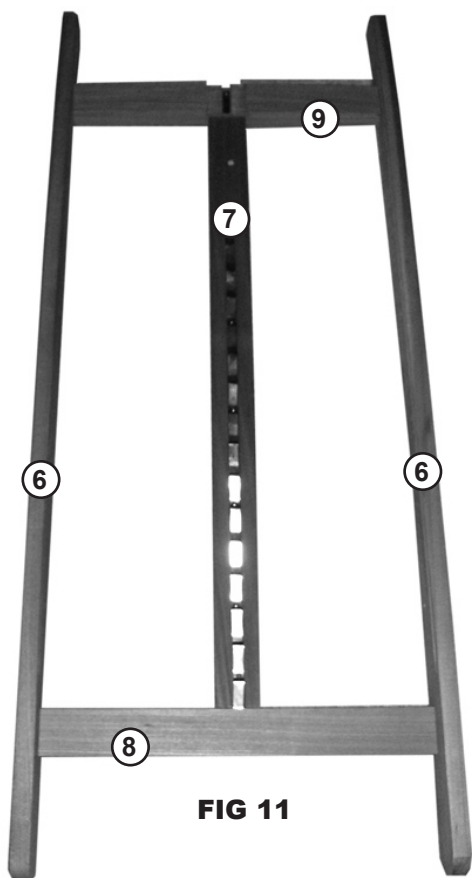

FIG 11

STEP 12. Attach assembled H-Frame to easel uprights found on assembled base. Make sure the metal ratchet front is facing out towards the front of the easel. This step involves securing the H-Frame assembly to the uprights of the easel base as shown in FIG 12.

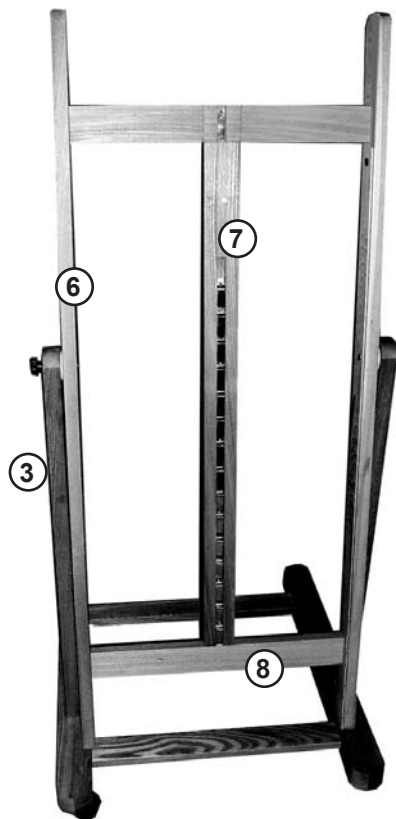

FIG 12

STEP 13. To secure the H-Frame to the uprights, have one person hold the H-frame while the other inserts one part (G) 6 X 70mm Bolt through the inside edge of the channelled sides and through the other side, then attach one wood washer to the bolt end. See FIG 13a.

Continue through the upright and secure with metal washer and black knob. See FIG 13b.

REPEAT with other side of H-Frame to complete this Step.

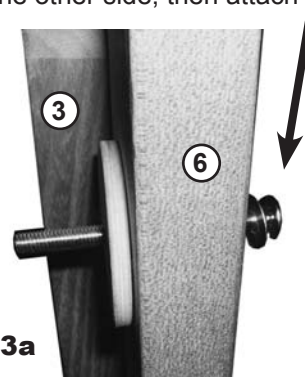

FIG 13a

The completed assembly should look like FIG 13b.

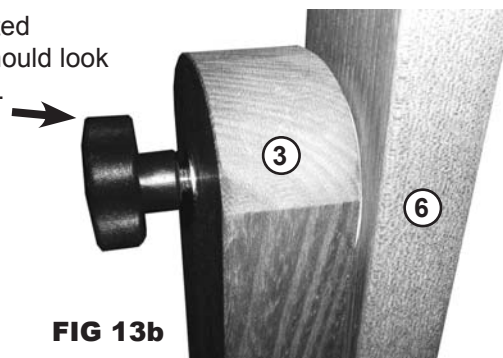

FIG 13b

STEP 14. Attach Extendable Rear Legs (10&11) to base (1) and upper portion of Channelled Sides (6). Attach the wider end of the adjustable Rear legs (10) to the base by securing with one 5 X 25mm Screw. See FIG 14 for proper location. Secure with Phillips screwdriver. Repeat with other Extendable Leg.

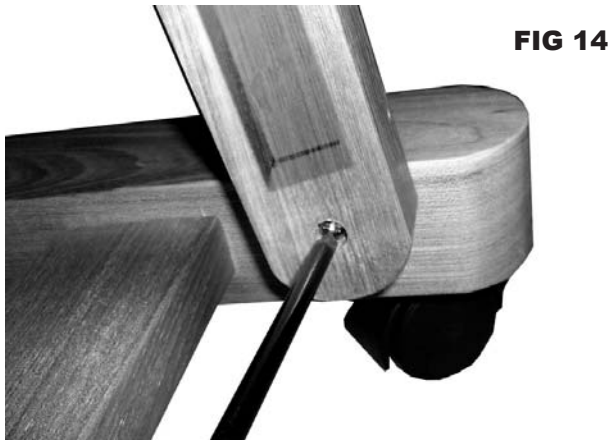

FIG 14

STEP 15. Attach upper portion of Extendable Rear Legs (11) to upper portion of Channelled Sides (6). Pull-out the narrower end of the extendable leg (11) and attach it to the inside edge of the channelled sides by inserting one 6 X 45mm bolt (H3) through the outside side of the channelled side continuing through the extendable leg (11) and then placing the metal washer over the bolt and tightening with the knob to secure. See FIG 15. See FIG 15b for proper view of assembly step 15.

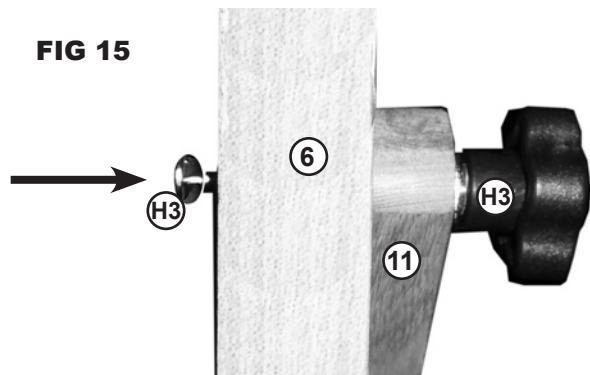
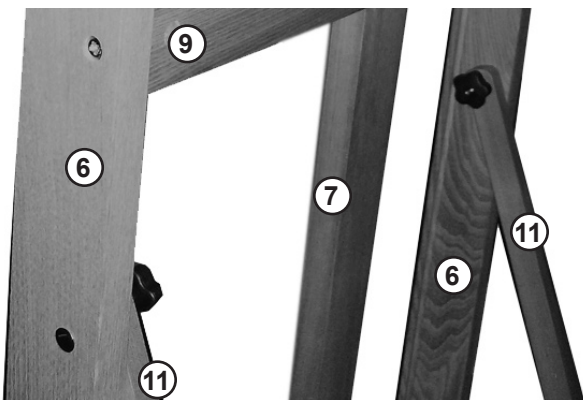

FIG 15

FIG 15b



STEP 16. Attach 6 X 40mm Bolts, knobs & washers (H4) to Extendable legs (10 & 11). These adjustment knobs are used along with the others to lower the easel into a horizontal position. Insert the bolt through the inside edge of the extendable leg (11), continue going through to the other side and complete with metal washer and knob. Tighten to secure. See FIG 16.

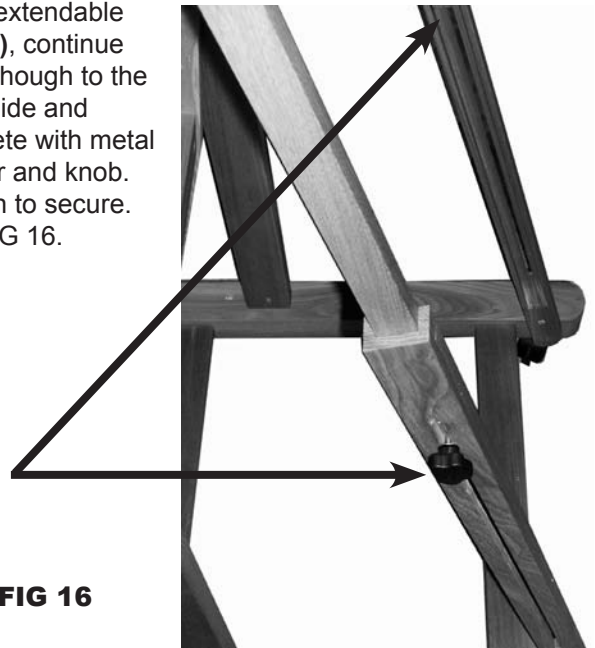

FIG 16

STEP 17. Loosen all knobs to lower the easel into the horizontal position. Once in flat position, tighten all knobs to secure. See FIG 17. This step involves inserting and sliding the Channelled Center Column (4) and Material tray (5) assembly through the upper cross member (indicated by the circle) and guiding the material tray corners into the channelled Sides (indicated by the squares). See FIG 17. See inset photos below for detail.

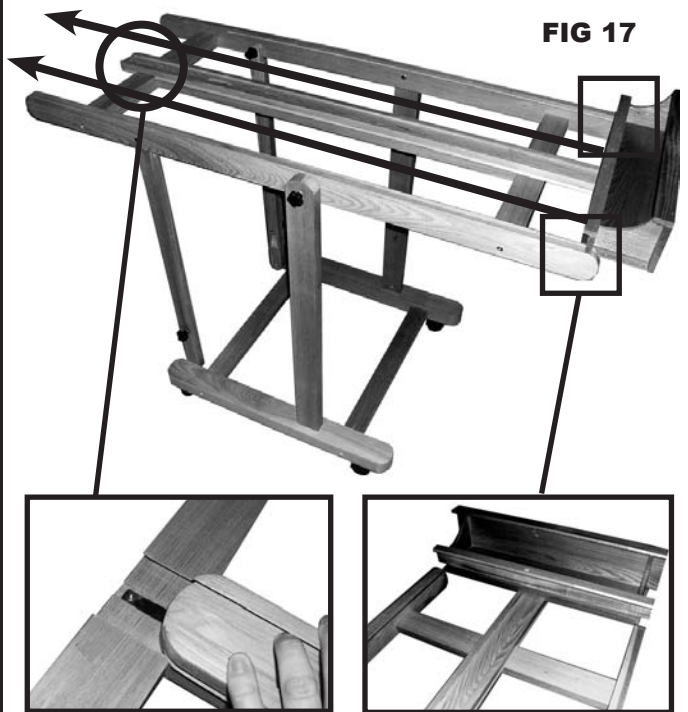

FIG 17

STEP 18. Once Channelled Center Column is in its proper location in the upper Cross Support, secure with the longest of the three remaining knobs by threading the threads of the knob in the hole in the rear of the cross support. Tighten to secure. See FIG 18.

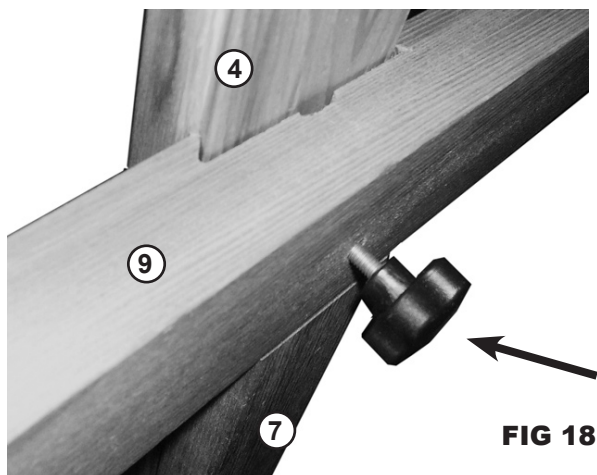

FIG 18

STEP 19. This step involves adding the Adjustable Center Column (12) down into the Channelled Center Column (4). See FIG 19. To secure into place, thread one of the remaining two shorter knobs into the hole found on the rear of the Channelled Center Column. See FIG 19b.

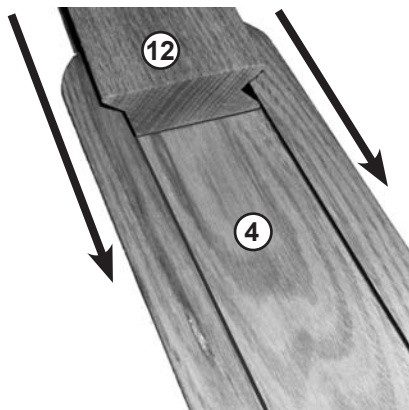

FIG 19

Rear view of Channelled Center Column where knob is to be threaded.

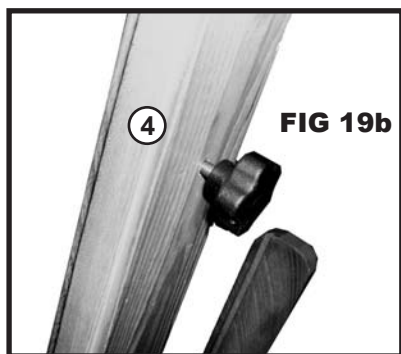

FIG 19b

STEP 20. Final step involved in the assembly of your New 92-3010 Easel. Attach the Upper Canvas Support (13) to the Adjustable Center Column (12) by sliding the grooves of the canvas support down into the channels of the Adjustable Center Column. Do this from the top end of the Adjustable Center Column. Secure with remain knob. tighten to secure at desired position. See FIG 20

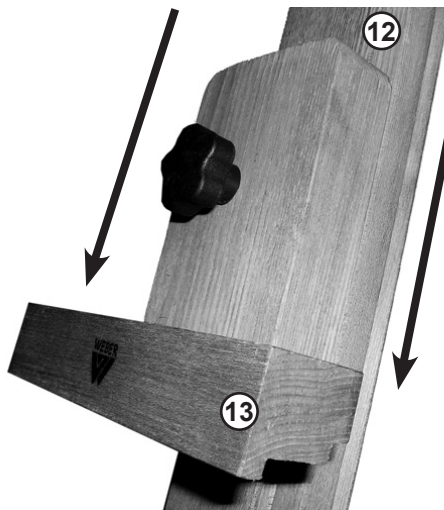
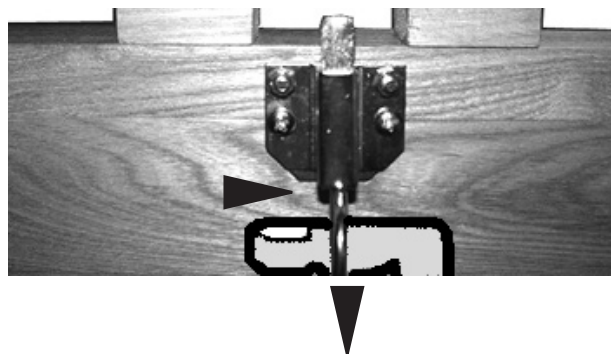

FIG 20

ADJ 1. Adjusting Height Material Tray.

Insert finger in locking loop pin below Material Tray and pull outward. This will cause the material tray support to release from the metal ratchet column allowing you to raise or lower the material tray and center column.



PLEASE NOTE: Be careful when raising the material tray, that you are aware that the top of the column will not interfere with ceiling or any other object in rooms that have low ceilings.

IMPORTANT

If you have difficulty assembling your 92-3010 Weber Monster Amalfi Studio Easel or need customer service assistance. Please call: Martin Universal Design, Inc. Customer Service Hot Line at 1-313-895-0700. If you need additional parts, it is not necessary to contact your dealer, our Customer Service Rep. will forward them to you immediately.



Martin/F. Weber Co. • 4444 Lawton Avenue, Detroit, MI 48208 USA
Tel:(313)895-0700 • Fax:(313)895-0709 • E-mail:Custservmud@aol.com
www.MartinUniversalDesign.com • www.weberart.com • Made in China

92-3010 Weber Monster Amalfi Studio Easel

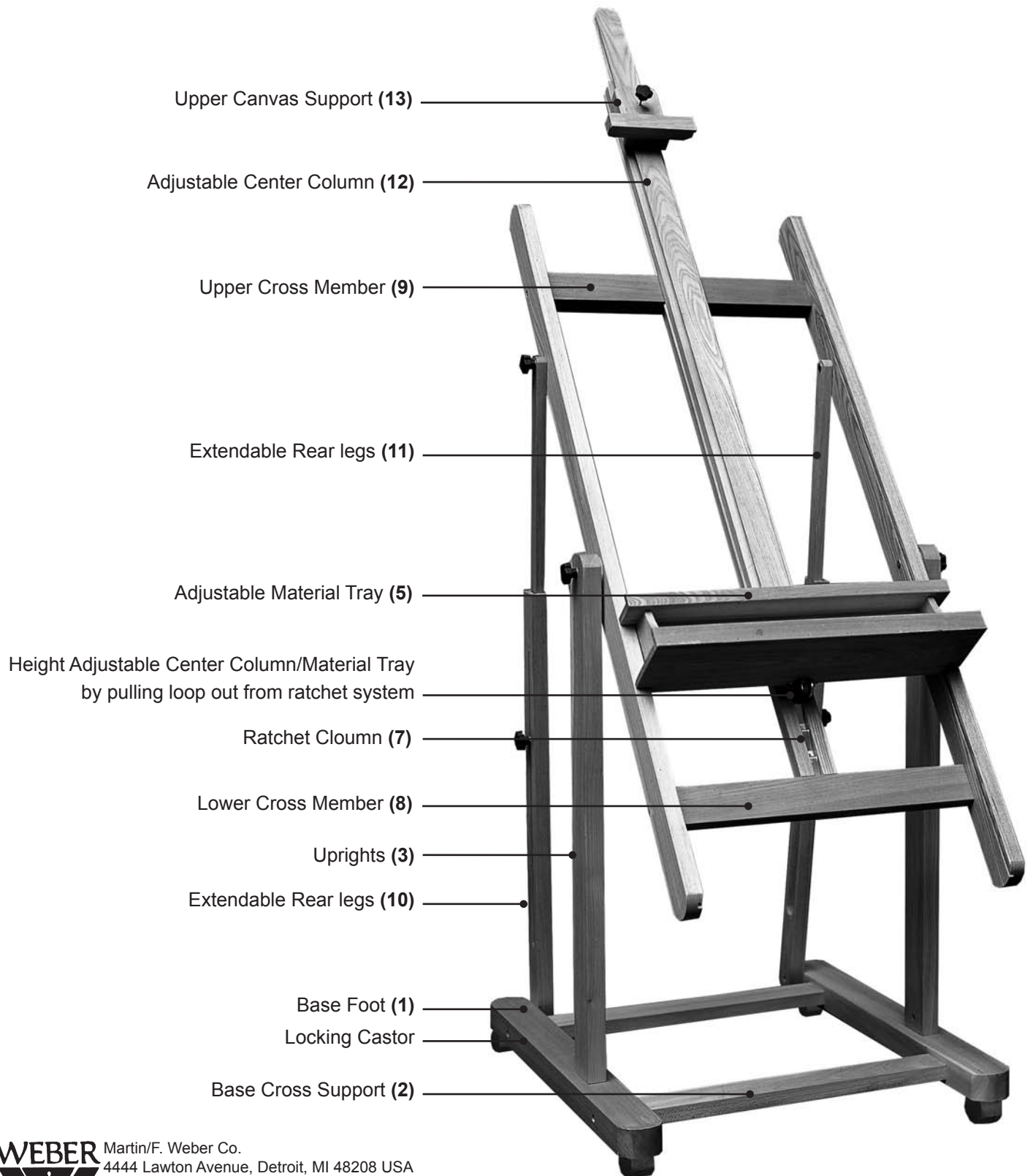

Martin/F. Weber Co.
4444 Lawton Avenue, Detroit, MI 48208 USA
Tel:(313)895-0700 • Fax:(313)895-0709
E-mail:Custservmud@aol.com
www.MartinUniversalDesign.com • www.weberart.com • Made in China

Created NOV07 RPI