







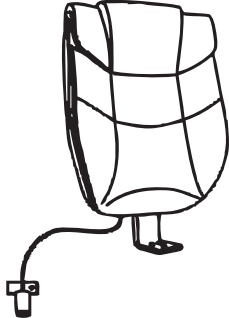

IMPORTANT NOTICE

You will feel a slight "Bounce-Back" when you sit down. This is normal, not a defect. The pneumatic cylinder for the seat height adjustment reacts to your weight by giving a little.

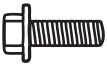
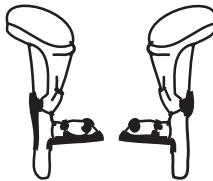
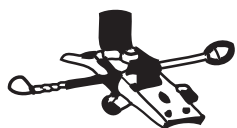
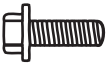
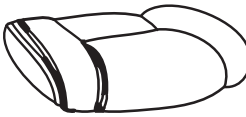
MARTIN CEO EZ CHAIR

PARTS LIST

91-6109115

<p>A</p>  <p>M6 x 20mm QTY: 3</p>	<p>G</p>  <p>Back Cushion with Lumbar Support</p>	<p>L</p>  <p>Castors QTY: 5</p>
<p>B</p>  <p>M6 x 30mm QTY: 6</p>	<p>H</p>  <p>Arms QTY: 2</p>	<p>M</p>  <p>Base Plate & Tilt Mechanism</p>
<p>C</p>  <p>M6 x 25mm QTY: 6</p>	<p>J</p>  <p>Seat Cushion</p>	<p>N</p>  <p>Desk Height Cylinder</p>
<p>E</p>  <p>Small Allen Wrench</p>	<p>K</p>  <p>5 Star Base</p>	<p>O</p>  <p>Black Bellow (Desk height only)</p>
<p>F</p>  <p>Large Allen Wrench</p>		

IMPORTANT

If you have difficulty assembling your chair or need customer service assistance, please call : Martin Universal Design, Inc. Customer service hot line at 1-800-366-7337. If you need additional parts, it is not necessary to contact your dealer. Our Customer Service Rep. will forward them to you immediately.

MARTIN

MARTIN UNIVERSAL DESIGN, INC

4444 Lawton Street, Detroit, MI 48208 USA

TEL: 313-895-0700 FAX: 313-895-0709

www.MartinUniversalDesign.com

Email: custservmud@gmail.com

Step 1:

Find (K) the Five Star Base and push the (L) Castors into the bottom of the base.

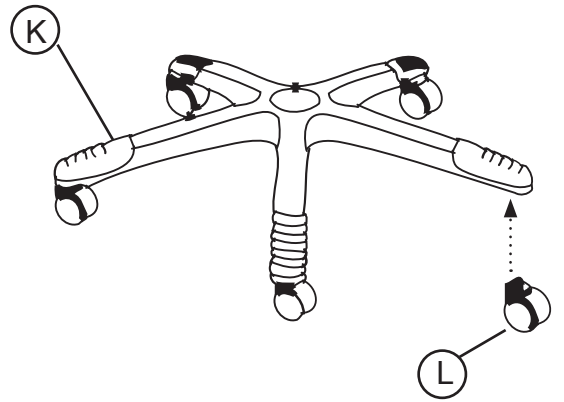

Step 2:

Place the (N) Cylinder in the middle of the base.

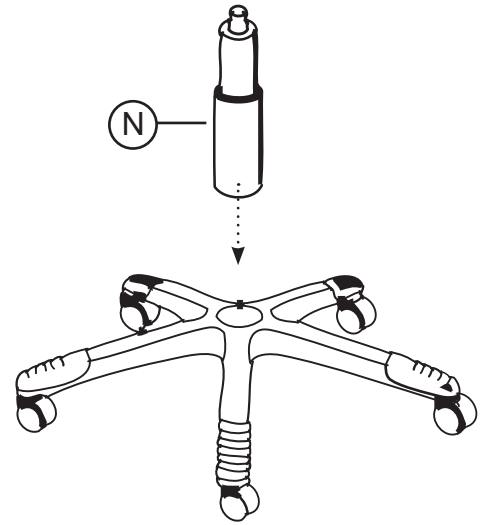

Step 3:

Now slide the (O) Black Bellow over the Cylinder.

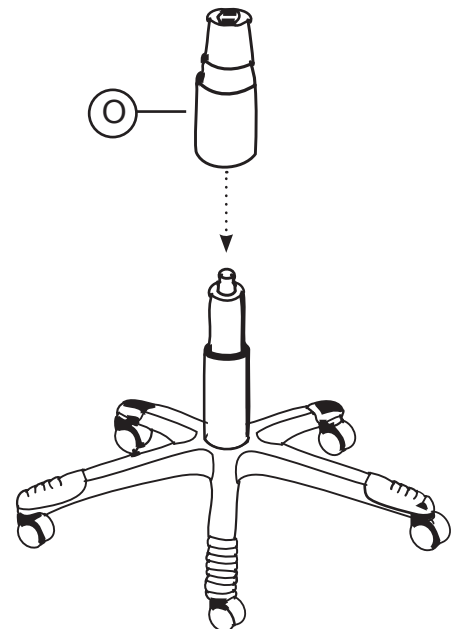

Step 4 :

Take the (J) Seat and turn it upside down so you can see the holes. Take the (M) Base Plate & Tilt Mechanism place on bottom of Seat (J) . The Big knob goes towards the front of the chair. Line up the holes and secure with 4 (C) M6x25mm Bolts using the (E) Small Allen Wrench.

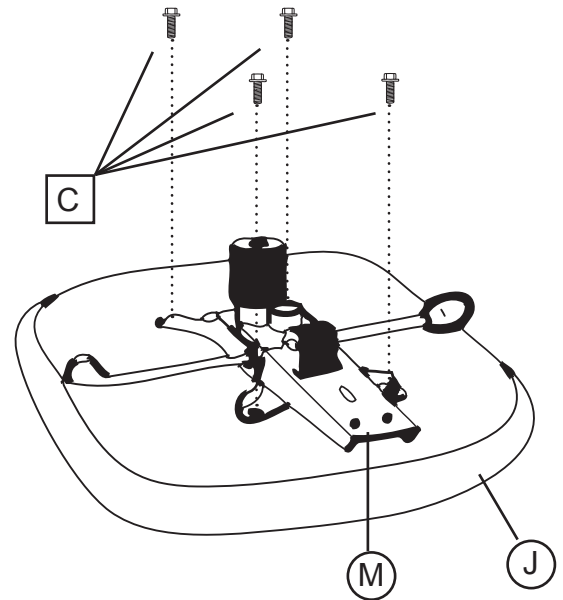

Step 5:

Take the (H) arms so the black curved part faces the front of the chair.

Line up the arm with the 3 holes on the bottom of the seat (J) . The holes make a triangle shape.

Secure to the Chair with 3 (B) M6x30mm bolts using the (E) small Allen Wrench

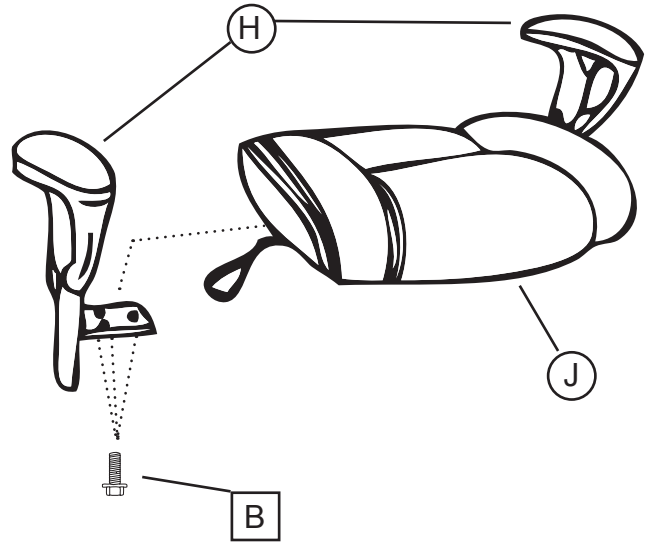

Step 6:

Take (G) Back Rest Cushion with Lumbar Support and slide the metal tab into the (M) and line up the holes. Now take (A) M6x20mm and tighten with the (F) Large Allen Wrench. Repeat this process for the other two remaining bolts.

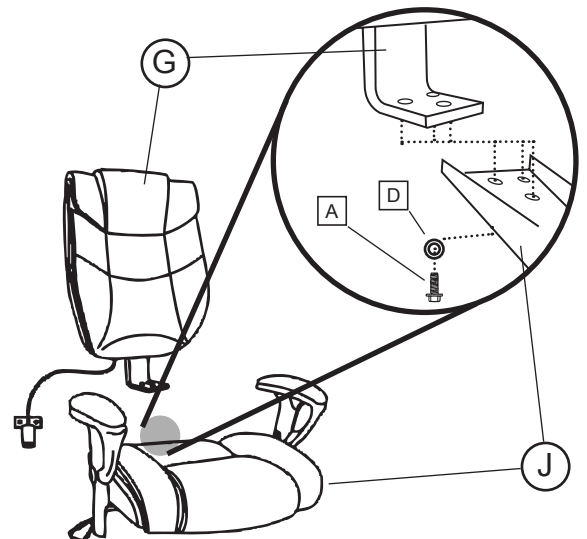

Step 7:

Place the pump which is already attached to the Back Rest (G) on the right side of the chair which should be the only remaining holes left. Fasten with (C) M6x25mm Bolts using the (E) Small Allen Wrench.

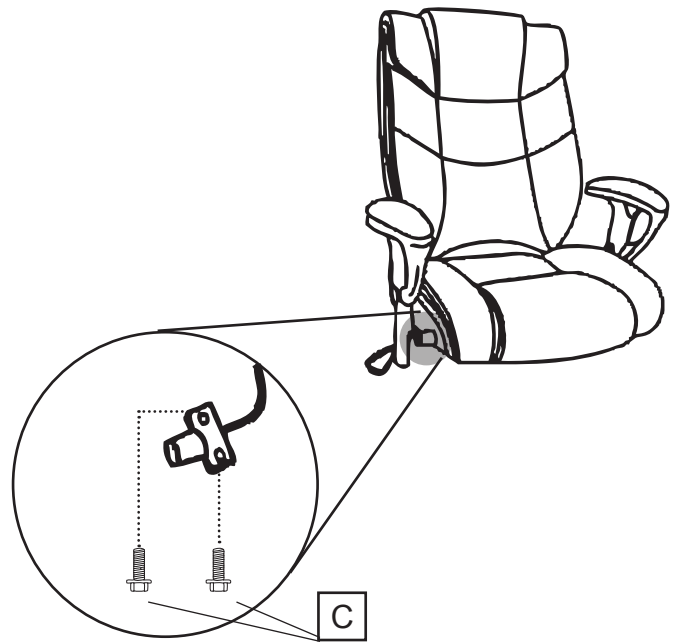

Step 7:

Take the assembled top part of the chair (Backrest and seat) and place over the cylinder in the open hole on the attached base.

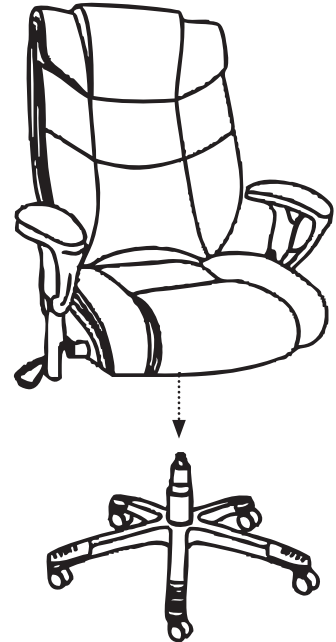

Adjusting the Martin CEO EZ Chair

- The Lever on the right hand side is for adjusting the height of your chair. You need to be in the chair for it to go down.
- The Lumbar support is the knob on the Right side of the chair. If you twist it forward it goes up and if you twist backwards it gets softer.
- The lever on the Left hand side of the chair locks the back in place or releases it allowing you to recline.
- The Large Knob on the bottom of the chair adjusts the pressure it takes to recline.