

# Comfort-Mesh Executive

## Assembly Instructions

91-02209115

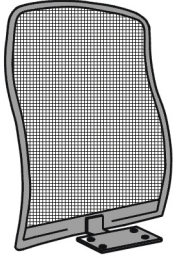

**A**

Backrest  
Qt. 1

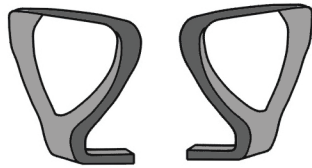

**B**

Armrest  
Qt. 2

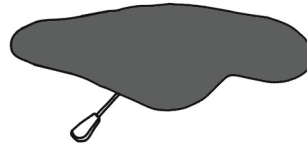

**C**

Seat  
Qt. 1

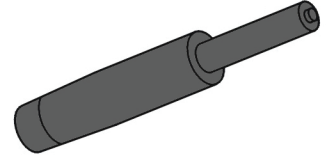

**D**

Cylinder  
Qt. 1

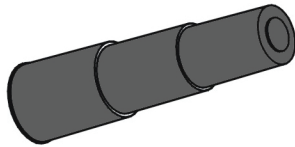

**E**

Black Cylinder Bellow  
Qt. 1

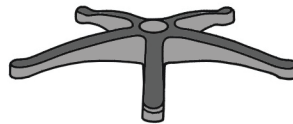

**F**

5-Star Base  
Qt. 1

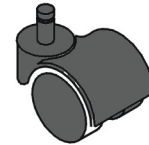

**G**

Castors  
Qt. 5

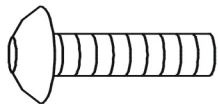

**H**

1" Black Screws  
Qt. 6

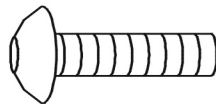

**I**

7/8" Black Screws  
Qt. 4



**J**

Hex Key  
Qt. 1

### IMPORTANT

If you have difficulty assembling your **Comfort-Mesh Executive 91-02209115**, or need customer service assistance, please call Martin Universal Design, Inc. Customer Service Hotline at 1-313-895-0700. If you need additional parts, it is not necessary to contact your dealer. Our Customer Service Rep. will forward them immediately.

**MARTIN**  
Universal Design, Inc.

4444 Lawton Avenue, Detroit MI, 48208 USA  
Tel: (313)895-0700 Fax: (313)895-0709  
Email: Custservmud@aol.com  
Visit us at: [www.martinuniversaldesign.com](http://www.martinuniversaldesign.com)

# 1

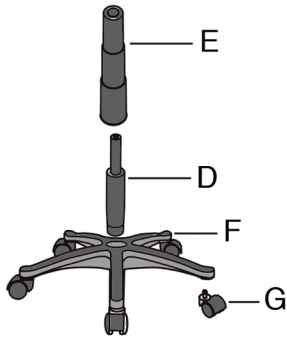

Place **Base (F)** face down and push **Castors (G)** in firmly. Insert **Cylinder (D)** through base cap into chair base. Twist and press firmly. Slide **Bellows (E)** down over cylinder.

# 2

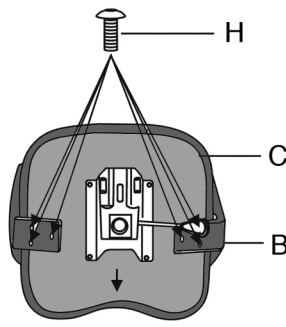

Attach **Armrests (B)** to **Seat (C)** using [6] **1" Black Screws (H)**. Line up holes in Armrest to holes in Seat.

*\*To avoid misalignment, Do not tighten screws until all are screwed in.*

# 3

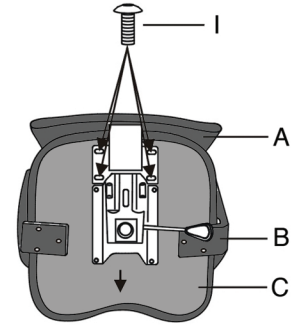

Attach **Backrest (A)** to **Seat (C)** using [4] **7/8" Black Screws (I)**. Line up holes in Backrest to holes in Seat.

*\*To avoid misalignment, Do not tighten screws until all are screwed in.*

# 4

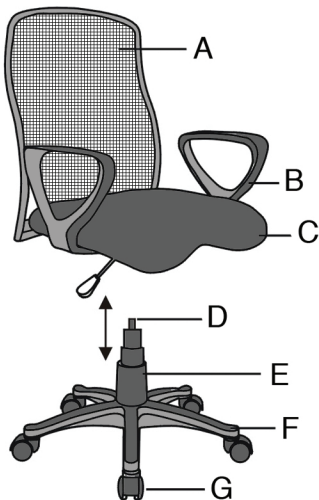

Take the complete **Seat assembly (A,B,C)**, and insert the seat assembly over **cylinder (D)** by inserting the cylinder into the hole on the bottom of the **Seat (C)**.



### IMPORTANT

If you have difficulty assembling your **Comfort-Mesh Executive 91-02209115**, or need customer service assistance, please call Martin Universal Design, Inc. Customer Service Hotline at 1-313-895-0700. If you need additional parts, it is not necessary to contact your dealer. Our Customer Service Rep. will forward them immediately.

# MARTIN

4444 Lawton Avenue, Detroit MI, 48208 USA  
 Tel: (313)895-0700 Fax:(313)895-0709  
 Email: Custservmud@aol.com  
 Visit us at: [www.martinuniversaldesign.com](http://www.martinuniversaldesign.com)